

Frontload Washer

Refer to Page 7 for Model Identification

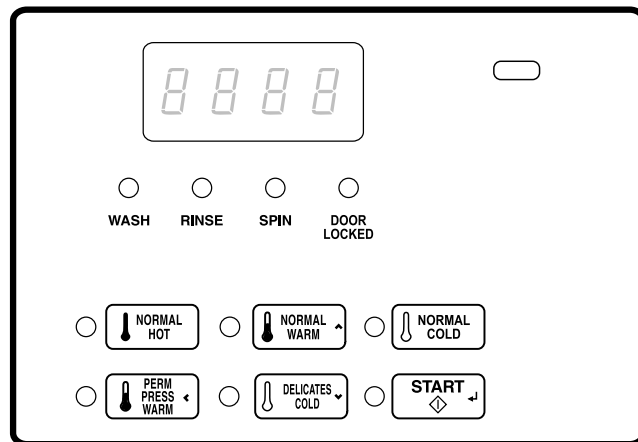

FLW88R_SVG

Original Instructions

Keep These Instructions for Future Reference.

CAUTION: Read the instructions before using the machine.

(If this machine changes ownership, this manual must accompany machine.)



WARNING

Failure to install, maintain, and/or operate this machine according to the manufacturer's instructions may result in conditions which can produce bodily injury and/or property damage.

W030



WARNING

For your safety and to reduce the risk of fire or an explosion, do not store or use gasoline or other flammable vapors and liquids in the vicinity of this or any other appliance.

W022

NOTE: The WARNING and IMPORTANT instructions appearing in this manual are not meant to cover all possible conditions and situations that may occur. It must be understood that common sense, caution, and carefulness are factors which cannot be built into these washers. These factors MUST BE supplied by the person(s) installing, maintaining, or operating the unit.

Always contact the distributor, service agent, or the manufacturer about any problems or conditions you do not understand.



Read all instructions before using unit.



Hazardous voltage inside. Disconnect power before servicing.

This product uses FreeRTOS V7.2.0 (www.freertos.org).

Table of Contents

Model Identification.....	7
Preliminary Information.....	9
About the Control.....	9
Glossary of Terms.....	9
Power Failure Recovery.....	9
Serial Card Reader Communications (Card Models Only).....	9
Control Identification.....	10
Select Cycle Pads.....	10
Display Identification.....	11
Light Emitting Diodes (LEDs).....	11
CYCLE LED.....	11
WASH LED.....	11
RINSE LED.....	11
SPIN LED.....	11
DOOR LOCKED LED.....	11
7-Segment Digits.....	11
Washer Operation.....	12
Power Up.....	12
Ready Mode.....	12
Partial Vend Mode.....	12
Additional Vend Mode.....	12
Start Mode.....	12
End of Cycle Mode.....	12
Door Locking Mode.....	12
Door Unlocking Mode.....	12
Cycle Sequence.....	12
Closing Washer Door.....	13
Signals.....	13
Changing Cycles.....	13
Special Features	14
Programming Control.....	14
Collecting Audit Information.....	14
Testing Machine and Control Functions.....	14
Rapid Advance Feature.....	14

© Copyright 2018, Alliance Laundry Systems LLC

All rights reserved. No part of the contents of this book may be reproduced or transmitted in any form or by any means without the expressed written consent of the publisher.

Clearing the Vend Feature	14
Communications Mode.....	14
Coin Drop.....	14
Start Pulse Operation.....	14
Service Door and Coin Vault Openings.....	14
OPL Mode.....	14
Opening the Service Door.....	15
Stacked Washers and Dryers, 10 Degree Front Control Washers and Coin Rear	
Control Washers.....	15
Rear Control Washers with Card Reader.....	15
OPL Models.....	16
Preparing for Manual Mode.....	16
Entering the Manual Mode.....	18
How to Enter the Manual Mode.....	18
Manual Mode Navigation.....	18
Programming Control.....	20
What Can Be Programmed.....	20
Programmable Options Available	20
Vend Price AtS.....	21
Coin 1 Value dEn1.....	22
Coin 2 Value dEn2.....	22
Start Pulse Value PLSE.....	23
Cycle Length CyCL.....	23
Default Cycle dCyC.....	23
Card Reader Display Control CARd.....	23
Audio Signal AUd.....	24
How to Program the Audio Signal.....	24
Error Code Programming Err.....	24
Water Level FLvL.....	25
Number of Balance Attempts with No Loss of Time bALA.....	25
OPL Parameters oPL.....	25
Collecting Audit Information.....	26
How to Enter Audit Feature.....	26
Entering the Audit Feature by Manual Mode.....	26
Entering the Audit Feature with the Coin Vault Open.....	26
How to Read Audit Data.....	26
How to Exit Audit Feature.....	26
Manual Reset.....	27
How to Enter Manual Reset.....	27
Testing Machine and Electronic Control Functions.....	28
How to Enter Testing Feature.....	28
How to Start Tests.....	28

How to Exit Testing Feature	28
Diagnostic (Testing) Mode – Quick Reference Chart.....	28
Diagnostic Test Descriptions.....	30
Control Software Version Number Test d 1.....	31
Drive Board #1 Software Test d 3.....	31
Water Level Trim Test d 7.....	31
Service Door Opening Test d 8.....	31
Coin Vault Opening Test d 9.....	31
Coin Drop 1 Input Test d 10.....	31
Coin Drop 2 Input Test d 11.....	31
Vend Connection Header Present Test d 12.....	31
Start Pulse Test d 13.....	32
Door Switch Input Test d 15.....	32
Door Lock Input Test d 16.....	32
Show Fill Time Test d 17.....	32
Show Drain Time Test d 18.....	32
Out of Balance Switch Test d 22.....	32
External Outputs Test d 23.....	32
Water Purge Test d 24.....	32
Water Leak Detection Test d 25.....	33
Water Level Test d 26.....	33
DC Bus Voltage Test d 27.....	33
AC Mains Voltage Test d 28.....	33
Configuration 1 Display Test d 29.....	33
Configuration 2 Display Test d 30.....	36
Configuration 3 Display Test d 31.....	36
Configuration 4 Display Test d 32.....	36
Configuration 5 Display Test d 33.....	37
Factory Test.....	37
To Enter Factory Test.....	37
To Exit Factory Test.....	38
.....	38

Error Codes 41

Rapid Advance Feature.....47

 How to Enter Rapid Advance.....47

 How to Exit Rapid Advance Feature.....47

Power Fail Recovery..... 48

Communications Mode..... 49

 Card Reader Communications - Card Models Only..... 49

Default Cycle Time 50

Model Identification

Information in this manual is applicable to these washer models:

BFNBCASG113TN01	HFNBEASP113CW01	HTGBYASP115TW01	STEBXASP133DW01
BFNBCASG113TW01	HFNBEASP115CW01	NTEBXASP303NW01	STEBXASP134DW01
BFNBCASP113TW01	HFNBXASP113CW01	NTEBXASP303NW22	STEBXASP134FW01
BFNBEASP113CN01	HFNBXASP113FQ01	NTEBXASP304NW01	STEBXASP173FW28
BFNBEASP113CW01	HFNBXASP113FW01	NTEBXASP304NW22	STEBXASP173TQ01
BFNBLBSP303AW01	HFNBXASP115CW01	NTEBXASP543NW23	STEBXASP173TW01
BFNBLBSP543NW01	HFNBXASP123DW01	NTEBYASP543NW23	STEBXASP175TW01
BFNBXASP113FW01	HFNBXASP303NW22	NTGBXASP303NW01	STEBXASP303NW22
BFNBXASP303AW01	HFNBXASP543DW01	NTGBXASP304NW01	STEBXASP303UW01
BFNBYASP113TW01	HFNBXRSP113FW01	NTLBXASP303NW26	STEBXASP304NW22
BTEBCASP173TW01	HFNBYASG113CW01	NTLBXASP304NW26	STEBXASP304UW01
BTEBEASP283CW01	HFNBYASG115CW01	NTLBXASP543NW23	STEBXASP304WW01
BTEBLASP433AW01	HFNBYASP113CW01	NTLBYASP543NW23	STEBXASP433AW01
BTEBLASP434AW01	HFNBYASP115CW01	SFNBCASG113TQ01	STEBXASP433AW12
BTEBXASG454NW36	HTEBCASP173TW01	SFNBCASG113TW01	STEBXASP434AW01
BTEBXASP173FW28	HTEBCASP175TW01	SFNBCASP113TQ01	STEBXASP434AW12
BTEBXASP433AW01	HTEBDASP283CW01	SFNBCASP113TW01	STEBXASP543DW01
BTEBXASP434AW01	HTEBDASP285CW01	SFNBCASP115TW01	STEBXASP543ZW01
BTEBYASP173TW01	HTEBXASP133DW01	SFNBCRSP113TW01	STEBXASP544DW01
BTGBCASP113TW01	HTEBXASP134DW01	SFNBCRSP113TW02	STEBXASP544ZW01
BTGBLASP303AW01	HTEBXASP134FW01	SFNBXASG083JW01	STEBYASP173TW01
BTGBLASP304AW01	HTEBXASP173FW28	SFNBXASG113JW01	STEBYASP175TW01
BTGBXASP113FW28	HTEBXASP283CW01	SFNBXASG113TQ01	STGBCASP113TW01
BTGBXASP303AW01	HTEBXASP285CW01	SFNBXASG113TW01	STGBCASP115TW01
BTGBXASP304AW01	HTEBXASP293CW01	SFNBXASP113FW01	STGBXASG113TW01
BTGBYASP113TW01	HTEBXASP295CW01	SFNBXASP113TQ01	STGBXASP113FW28
BTLBXASG304NW36	HTEBXASP304NW22	SFNBXASP113TW01	STGBXASP113TW01
BTLBXASP304NW22	HTEBXASP543DW01	SFNBXASP115TW01	STGBXASP114FW01
HFNBCASG113TN01	HTEBXASP544DW01	SFNBXASP123DW01	STGBXASP115TW01
HFNBCASG113TQ01	HTEBYASP283CW01	SFNBXASP303AW01	STGBXASP123DW01
HFNBCASG113TW01	HTEBYASP285CW01	SFNBXASP303AW12	STGBXASP124DW01

Table continues...

Model Identification

HFNBCASG115TQ01	HTGBCASP113TW01	SFNBXASP303NW22	STGBXASP303AW01
HFNBCASG115TW01	HTGBCASP115TW01	SFNBXASP303ZQ01	STGBXASP303AW12
HFNBCASP113TN01	HTGBDASP093CW01	SFNBXASP303ZW01	STGBXASP303NW22
HFNBCASP113TQ01	HTGBDASP095CW01	SFNBXASP543DW01	STGBXASP303ZW01
HFNBCASP113TW01	HTGBXASP093CW01	SFNBXRSP113TW01	STGBXASP304AW01
HFNBCASP115TQ01	HTGBXASP095CW01	SFNBXRSP113TW02	STGBXASP304AW12
HFNBCASP115TW01	HTGBXASP113FW28	SFNBXRSP115TW02	STGBXASP304NW22
HFNBCRSP113TW01	HTGBXASP114FW01	SFNBYASP113TW01	STGBXASP304ZW01
HFNBCRSP115TW01	HTGBXASP123DW01	SFNBYASP113TW01	STGBXASP543DW01
HFNBDASG113CW01	HTGBXASP124DW01	SFNBYASP115TW01	STGBXASP544DW01
HFNBDASG115CW01	HTGBXASP543DW01	SFNBYRSP113TW01	STGBYASP113TW01
HFNBDASP113CW01	HTGBXASP544DW01	SFNBYRSP115TW01	STGBYASP115TW01
HFNBDASP115CW01	HTGBYASP093CW01	STEBASP173TQ01	TTEBXASP303NW22
HFNBDRSP113CW01	HTGBYASP095CW01	STEBASP173TW01	TTEBXASP304NW22
HFNBDRSP115CW01	HTGBYASP113TW01	STEBASP175TW01	

Preliminary Information

About the Control

This control is an advanced, programmable computer that lets the owner control most machine features by pressing a sequence of keypads.

The control allows the owner to set vend prices, retrieve audit information, run diagnostic tests and set other programmable features. Washers shipped from the factory have a default cycle setting of NORMAL COLD built in. However, the owner can change the default cycle, or any cycle, as needs permit.

IMPORTANT: In the event of a power failure, the control will not have to be reprogrammed. It is designed with a memory system that will remember how it was programmed until the electrical power is restored.

IMPORTANT: It is extremely important that the washer has a good ground connection and that all mechanical and electrical connections to the control are made before applying power to or operating the washer.

Glossary of Terms

The following are a few terms and abbreviations to learn. These are referred to throughout the instructions.

Display – This term refers to the window area of the control that displays words and values.

LED (Light Emitting Diode) – This term refers to the lights next to the keypads and status words of the control.

FEC – Front End Control

I/O Board – Input/Output Board

OPL – On Premises Laundry

Power Failure Recovery

If a cycle is in progress and the power fails, the cycle status is saved in memory. When the power recovers, the washer will resume into the previously active cycle if so programmed by the owner.

The owner may program a special feature called POWER FAIL RESET which sets a maximum power failure duration. To program this feature, refer to *Programming Control*.

If the length of the power failure is greater than the POWER FAIL RESET time, the control will end the cycle and the display will revert back to the ready mode.

On drain pump models, if the wash basket is full of water, the control will lock the door and pump out the water.

Serial Card Reader Communications (Card Models Only)

The control will accept communication with a serial card reader in order to perform vending transactions when a card is inserted to pay for cycles. The card reader can also allow the owner to program a limited number of features and collect audit information.

For detailed information on serial card reader communications, refer to instructions included with card reader.

Control Identification

Select Cycle Pads

SELECT CYCLE pads are used to select the specific washer cycle. These pads include NORMAL HOT, NORMAL WARM, NORMAL COLD, PERM PRESS WARM and DELICATES COLD. These pads allow the user to select a cycle other than the default cycle (NORMAL COLD).

The SELECT CYCLE keypads are not active after the first fill step of the cycle. The selected cycle is indicated by the light (LED) on the pad. Pressing the flashing START pad will confirm the selection and the cycle will begin.

When a card reader is used, pressing the START pad will start the cycle and deduct the vend price from the card.

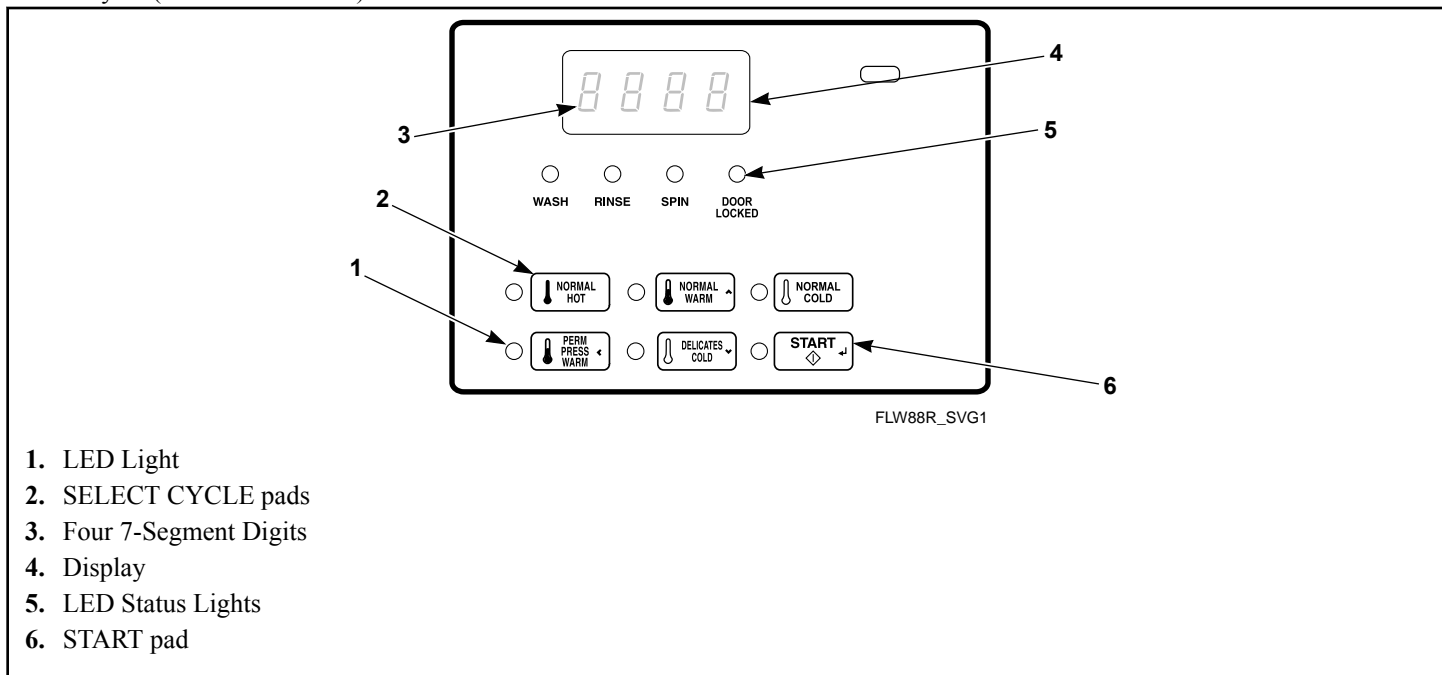

Figure 1

Display Identification

Light Emitting Diodes (LEDs)

LIGHT EMITTING DIODES (LEDs) are used to indicate the chosen cycle and cycle status. See below for information on each LED.

CYCLE LED

CYCLE LED will remain lit the entire cycle.

WASH LED

WASH LED is lit at the beginning of a wash portion of the cycle and will remain lit until the wash is complete.

RINSE LED

RINSE LED is lit at the beginning of a rinse portion of the cycle and will remain lit until the rinse is complete.

SPIN LED

SPIN LED is lit during the Final Spin portion of the cycle.

DOOR LOCKED LED

DOOR LOCKED LED is lit whenever the door is locked. The door can't be opened when this LED is lit.

7-Segment Digits

The 7-SEGMENT DIGITS are used to display the time remaining in a cycle, vend price, error messages and descriptive codes. During diagnostic testing or manual programming of the control, these digits will display descriptive codes and values.

Washer Operation

Power Up

When power is applied to the washer, the control will display its control type as *FL*, software version as *5HHH* (*HH* is the version number) for one (1) second each. If the control was not powered down during a running cycle, it will enter the Ready Mode.

Ready Mode

In this mode of operation the display shows the current selected cycle, and the full current vend price for that cycle.

To start the cycle, the user must satisfy the vend price and then press the START keypad.

The user will be able to select a different cycle by pressing a cycle pad when the machine is in the ready mode or before the first fill is complete.

Partial Vend Mode

The control enters this mode when part of the vend price has been entered but not enough vend is entered to satisfy the vend price. The control will display the remaining vend price needed to start the cycle.

Additional Vend Mode

The control enters this mode if a change is made before the first fill is complete. If the vend price is not satisfied within one (1) minute, the washer control will go back to the first selection and the cycle will continue. Pressing the START keypad will cancel cycle changes and exit this mode. After the first fill, all key presses will be ignored, allowing the washer to go through the complete cycle.

Start Mode

The control enters this mode when the full vend price is satisfied, the vend price is zero, or the control is in OPL Mode. The START pad LED will flash one (1) second on and one (1) second off. If Start Mode is entered because the vend price is satisfied or the control is in OPL Mode, the display will show *PUSH* for one (1) second, *SETE* for one (1) second and the current cycle time for one (1) second. If Start Mode is entered because the vend price is zero (0), the display will show *FREE*. When first entering Start Mode, a signal will sound for one (1) second on and one (1) second off for 10 seconds if Signal for Start is enabled.

After pressing the START keypad, the door will lock and the cycle will begin.

End of Cycle Mode

When a cycle is complete, the control will display *DD* until the washer is opened, a key is pressed, or a coin/card is entered. When one of these three options occurs, the display will revert back to the ready mode.

Door Locking Mode

The control enters this mode after the Start pad is pressed in Start Mode or Pause Mode to start or resume a machine cycle. The control will stay in Door Locking Mode until the loading door is closed and locked. The control shows the remaining cycle time and the Door Lock LED flashes one second on/off.

Once the door is locked, the control will exit Door Locking Mode and will enter Run Mode. If the door is opened prior to being locked, the control will return to Start Mode.

Door Unlocking Mode

This mode is entered when there is no time left in the cycle or when pausing the cycle while in Run Mode. The door will unlock after the basket stops spinning. The display will continue to flash the remaining cycle time every second or if the next mode is End of Cycle Mode, it will flash *DI* every second. If the next mode is Pause Mode, the display will flash *PAUS* every second. If the drive board determines that the water temperature is too hot to drain or unlock the door, the display will flash *Hot* in addition to the other displays.

The machine will always drain water down to an empty level before attempting to unlock the door. If after the programmed time of draining, the water level is still not low enough, the control will enter Machine Error Mode with a drain error, if enabled. Otherwise the control will continue to drain until it sees the machine empty.

The Start key can be pressed while in this mode as long as Machine Error Mode or End of Cycle Mode is not the next mode. If the Start key is pressed and the next mode is Pause Mode or Start Mode, the next mode entered will be Door Locking Mode. Otherwise the press is invalid. All other keys are invalid while in this mode. Once Door Unlocking Mode is exited, the control will enter the next mode.

Cycle Sequence

Upon the start of a cycle, the control will display the total cycle time. The appropriate LEDs will light while the machine passes through different cycle steps. Any coin entered after the first fill completes will be added to the total coin counter, but the user will not be able to change cycles.

Closing Washer Door

If the door is not closed when the vend price is satisfied, **CLo5** and **dOoR** will be displayed until the door is closed. Once door is closed, the START pad must be pressed to lock door and start the cycle. If the door does not lock within 20 seconds of being closed, **EdL 1** will be displayed, indicating a door lock error, while the door continues to try to lock.

If the door locks after 20 seconds, the door lock error will clear and the cycle will continue normally. The door can be opened to clear the door lock error as well.

Signals

There are five options when a signal can be used during the washer operation. These five options are listed below:

1. **End of Cycle Signal** By default, this signal is turned off. If turned on, the signal sounds for three (3) seconds at the end of a cycle.
2. **Signal On Keypad Depression** By default, this signal is turned on and sounds for a quarter of a second each time a keypad is pressed.
3. **Signal On Coin Input/Card Insertion** By default, this signal is turned on and will sound for a quarter of a second each time a coin or card is entered.
4. **Signal for Serial or Network Vending Command** By default, this signal is turned on for a quarter of a second when the control receives a valid serial or network vend command.
5. **Signal for Start** By default, this signal is turned on and will sound one (1) second on and one (1) second off for 10 seconds after vend price has been satisfied.

NOTE: Refer to *Programming Control* to program signal options.

Changing Cycles

Cycles can be changed any time before the first fill is complete. After the first fill is complete, all key presses are ignored.

Selecting a higher priced cycle will pause the cycle until the vend price has been satisfied. After the vend price has been satisfied, the cycle will continue with the new selection. If the vend price is not satisfied within 1 minute, the washer control will go back to the previously set cycle.

Special Features

Programming Control

The control allows the owner to program the control with the use of the keypad. Cycle and vend information may be programmed, audit information may be viewed and diagnostic tests may be run by pressing keypad combinations.

Collecting Audit Information

The control stores audit information in its memory that can be retrieved by pressing various combinations of Select Cycle pads.

For more information on the audit features, refer to *Collecting Audit Information*.

Testing Machine and Control Functions

Special diagnostic features built into the control allow the owner to run specific diagnostic tests. By opening and closing the service door and then pressing various sequences of Select Cycle pads, the owner may perform the following tests:

- Control Software Version # Test
- Drive Board #1 Software Version Test
- Service Door Switch Input Test
- Coin Vault Switch Input Test
- Coin Drop #1 Input Test
- Coin Drop #2 Input Test
- Vend Connection Header Present Input Test
- Start Pulse Input Test
- Door Switch Input Test*
- Door Lock Switch Input Test*
- Show Fill Time Test
- Show Drain Time Test
- Out of Balance Switch Input Test
- External Output Test*
- Water Purge Test*
- Water Leak Detection Test*
- Water Level Test
- DC Bus Voltage Test
- AC Mains Voltage Test
- Machine Configuration #1 Display Test
- Machine Configuration #2 Display Test
- Machine Configuration #3 Display Test
- Machine Configuration #4 Display Test
- Machine Configuration #5 Display Test

* Tests can only be entered when in Start or Ready Mode.

For detailed information on running diagnostic tests, refer to *Testing Machine and Electronic Control Functions*.

Rapid Advance Feature

This feature allows the user to quickly advance through an active cycle or advance into a cycle from the Ready Mode. This feature is useful when tests must be performed immediately on a machine currently in an active cycle. In this case, the user can quickly advance through the cycle to the Ready Mode. At this point, the user can perform the required tests and then return the machine to the active cycle.

Clearing the Vend Feature

This feature allows the user to return the control back to the Ready Mode if coins have been entered but the full vend price has not yet been satisfied, while in Partial Vend Mode.

For more information on using the Clear Vend feature, refer to *Clear Vend Feature*.

Communications Mode

This feature allows the control to communicate with an external device or a card reader. This allows the control to be programmed and have its data read without using the keypad.

Coin Drop

The control will accept pulses from a single or dual coin drop to satisfy vend price. Each coin drop will have the ability to satisfy the vend.

Start Pulse Operation

The control will accept pulses from optional payment systems. The Start Pulse Mode allows the machine to go from the Ready Mode to the Start Mode after pulses are received.

Service Door and Coin Vault Openings

The control will capture the times and dates of the last seven openings of the Coin Vault and the Service Door. The information is saved in memory. An open service door and a closed coin vault combined with various keypad presses allows the control to enter manual modes of operation if the Break-In Alarm is not on. These modes include Manual Programming, Audit Collection, Diagnostics, Rapid Advance, and Reset to Factory Defaults.

OPL Mode

This feature allows the user to start a cycle without satisfying the vend price.

For details on enabling OPL Mode, refer to *Programming Control*.

Opening the Service Door

Stacked Washers and Dryers, 10 Degree Front Control Washers and Coin Rear Control Washers

Models through Serial No. 1810000001

Manual programming requires the user to open and close the service door. Opening and closing the service door trips a switch allowing access to various programming options, diagnostics, and audit capabilities. On coin models, the coin vault switch must be closed to enter Manual Mode.

Models starting Serial No. 1810000001

Manual programming requires the user to unplug the bullet connector located between the “white/black” and “red/blue” wires. Reconnect the connector for normal operation.

After opening and closing the service door or unplugging the bullet connector, the programmer has 4.25 minutes to begin programming. If a keypad has not been pressed in that time, the control will revert back to the Ready Mode. Refer to *Figure 2*.

The service door is located in the control panel on the Stacked Washer and Dryers and Front Control Washers. On Rear Control Washers, the service door is located on the top of the meter case. Refer to *Figure 2*.

Rear Control Washers with Card Reader

Manual programming requires the user to remove the control panel and unplug the bullet connector located between the “white/black” and “red/blue” wires. This will allow the user to access various programming options, diagnostics, and audit capabilities. Refer to *Figure 2*.

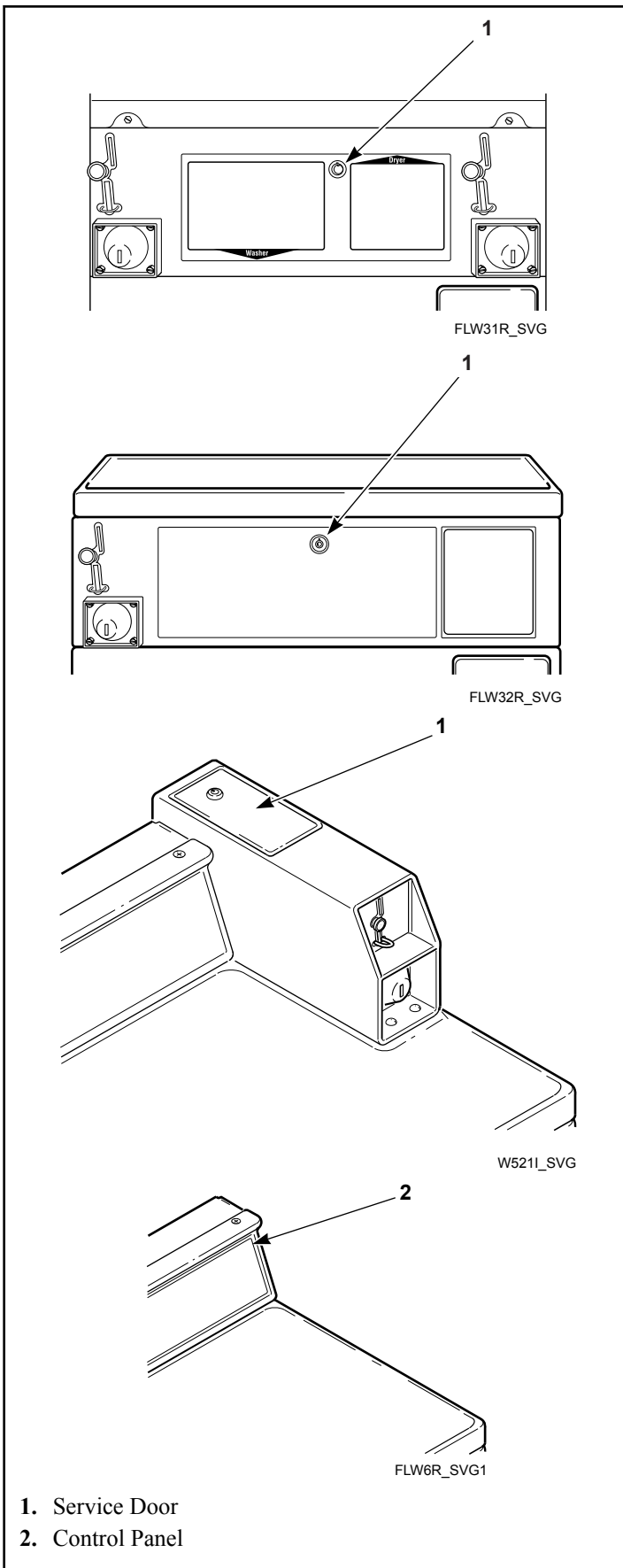

Figure 2

OPL Models

Preparing for Manual Mode

Manual programming requires the user to remove the cabinet top or control panel and unplug the bullet connector located between the “white/black” and “red/blue” wires. This will allow the user to access various programming options, diagnostics, and audit capabilities. Refer to *Figure 3*.

Single Units

1. Remove the screws from the back of the top panel that attach the top panel to the machine.
2. From the back of the machine, using a screwdriver, pry the top panel upward and towards you.
3. Remove the screws from the top of the control panel that attach the control panel to the machine.
4. Remove the screws from the bottom of the control panel that attach the control panel to the machine.

NOTE: When reinstalling the control panel, be sure to align the control panel’s tabs with the machine’s tabs.

Stack Units

1. Remove the screws from the bottom of the dryer front panel.
2. Remove the screws that attach the bottom of the dryer base to the frontload washer’s control panel.
3. To gain access to the control panel’s components, tilt the dryer back slightly and insert a 27-inch 2 x 2 between the dryer and washer.
4. As an alternative, remove the control panel using putty knives.
 - a. Insert a thin putty knife between the frontload washer’s control panel and front panel to disengage the control panel’s tabs.
 - b. The control panel’s tabs are located 8.71 inches from the edge of the left and right side panels.

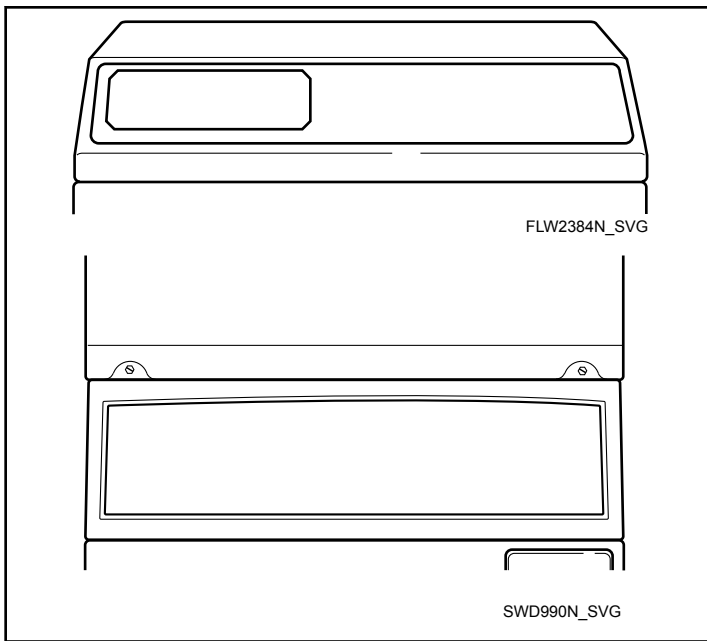

Figure 3

Entering the Manual Mode

How to Enter the Manual Mode

For programming, testing, and retrieving information from the control, it is often necessary to enter the Manual Mode by following the four simple steps below. For an overview of entering the Manual Mode, refer to the flowchart on the following page.

1. If accessing Diagnostic Tests that take control of machine operation, be sure the washer is in the Start or Ready Mode before continuing to step 2. If the washer is in an active cycle, rapid advance through the cycle. Refer to *Rapid Advance Feature*.
2. Stacked Washers and Dryers, 10 Degree Front Control Washers and Coin Rear Control Washers through Serial No. 1810000001: Open the service door. The coin vault switch must be closed.
3. All Other Models: Open the service door, if necessary, and unplug bullet connector.
4. While pressing and holding the PERM PRESS WARM keypad with one hand, press the NORMAL HOT keypad with the other hand.
5. The display will show *rAPd*.
6. Press the NORMAL WARM (Λ) or the DELICATES COLD (V) keypad to scroll through the options until the desired option appears in the display.

7. Press the START (enter) keypad.

NOTE: After entering Manual Mode, if no keypads are pressed for 4.25 minutes, the control will return to the previous mode of operation.

8. To exit, press the PERM PRESS WARM (<) keypad. The control will revert back to Ready Mode.

Manual Mode Navigation

Manual Mode is broken into five groups: Manual Programming, Manual Read Audit, Manual Reset, Manual Rapid Advance and Manual Diagnostics.

The manual features available in each group are as follows (the menu shown on the display in this mode is in parentheses).

- Manual Programming (*PrOG*)
- Manual Read Audit (*RUdt*)
- Manual Reset (*rSEt*)
- Rapid Advance (*rAPd*)
- Manual Diagnostic Tests (*d iAG*)

- Manual Mode: Enter by opening the service door for at least 1 second and then closing service door. Then press PERM PRESS WARM and NORMAL HOT keypads at the same time.
- Press the NORMAL WARM or DELICATES COLD keypad to scroll through the Manual Mode options.
- Press the START keypad to enter any sub-menu options.

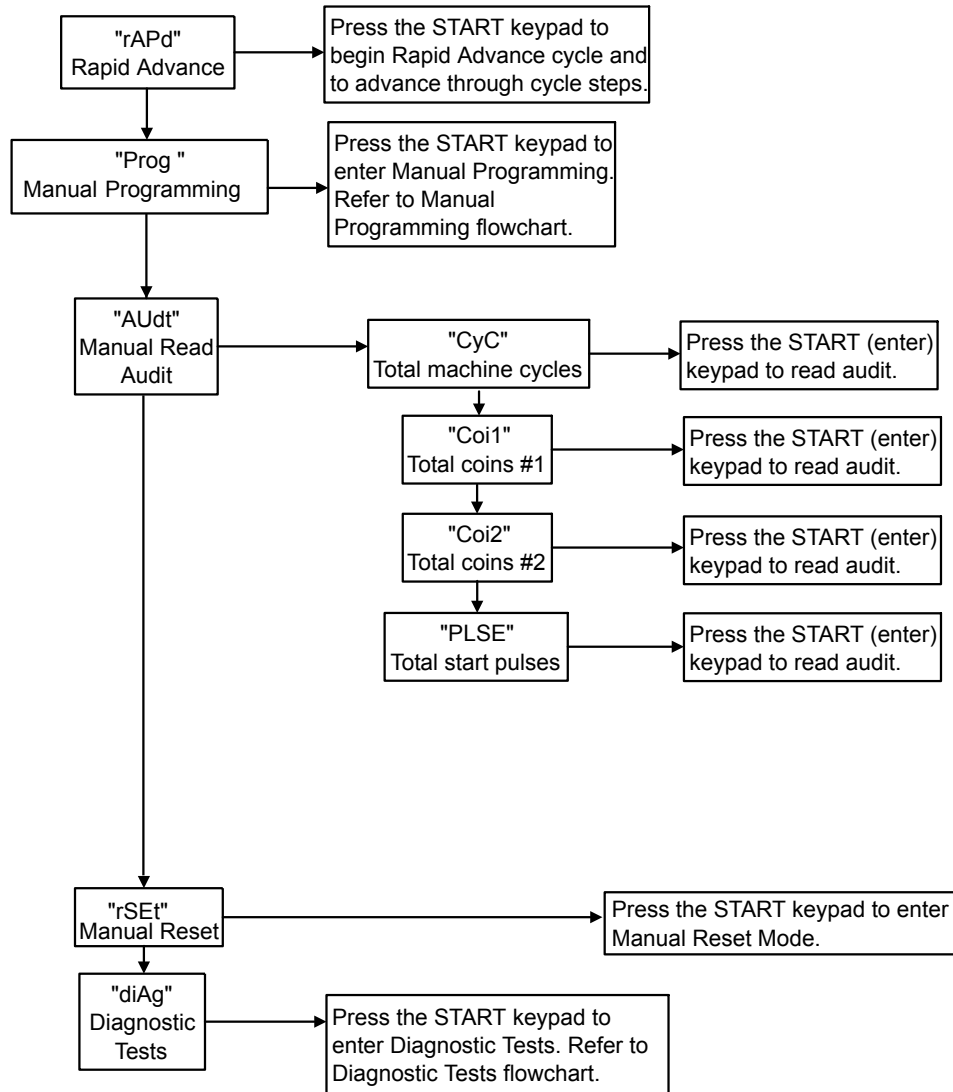

FLW145R_SVG

Figure 4

Programming Control

What Can Be Programmed

This feature allows the owner to program cycle information, standard vend pricing and other features by using the keypads. The control must have the Manual Programming Mode enabled, which is the factory default.

Refer to this section when programming the control. This section offers a detailed description of all options available to program.

Each description includes instructions on when and why the option might be used and, more importantly, how to program the option.

For an overview of the programming organization, refer to the flowcharts on the following pages.

For more advanced users, a quick reference list of the options available through the programming mode is located on this page.

NOTE: The letters and numbers in the Option Display column of the Programmable Options List are what will be shown in the display when that option is selected.

Programmable Options Available

Option Number	Option Display	Description	Factory Default	Value Range
1	<i>RE5</i>	Vend Price	200	0 - 65,535
2	<i>dEn1</i>	Coin #1 Value	25	1 - 65,535
3	<i>dEn2</i>	Coin #2 Value	100	1 - 65,535
4	<i>PL5E</i>	Start Pulse Value	25	1 - 65,535
5	<i>CYCL</i>	Cycle Length	3	3 - 5
6	<i>dCYC</i>	Default Cycle	3	1 - 5
7	<i>CRrd</i>	Card Reader Display Control	oFF	on/oFF
8	<i>AUd</i>	Audio Signal	on	on/oFF
9	<i>Errr</i>	Errors Menu	on	on/oFF
10	<i>SUd 1</i>	Suds Removal Routine Display	oFF	on/oFF
11	<i>SUd 2</i>	Suds Removal Routines Allowed Per Cycle	1	0-10
12	<i>SUd 3</i>	Suds Removal Routine Extra Time	on	on/oFF
13	<i>FLuL</i>	Water Level	10	1 - 30
14	<i>bALA</i>	Number of Balance Attempts with No Loss of Time	Through Serial No. 1506011826 = 4 Starting Serial No. 1506011827 = 7	1-7
15	<i>oPL</i>	OPL Mode	oFF	on/oFF

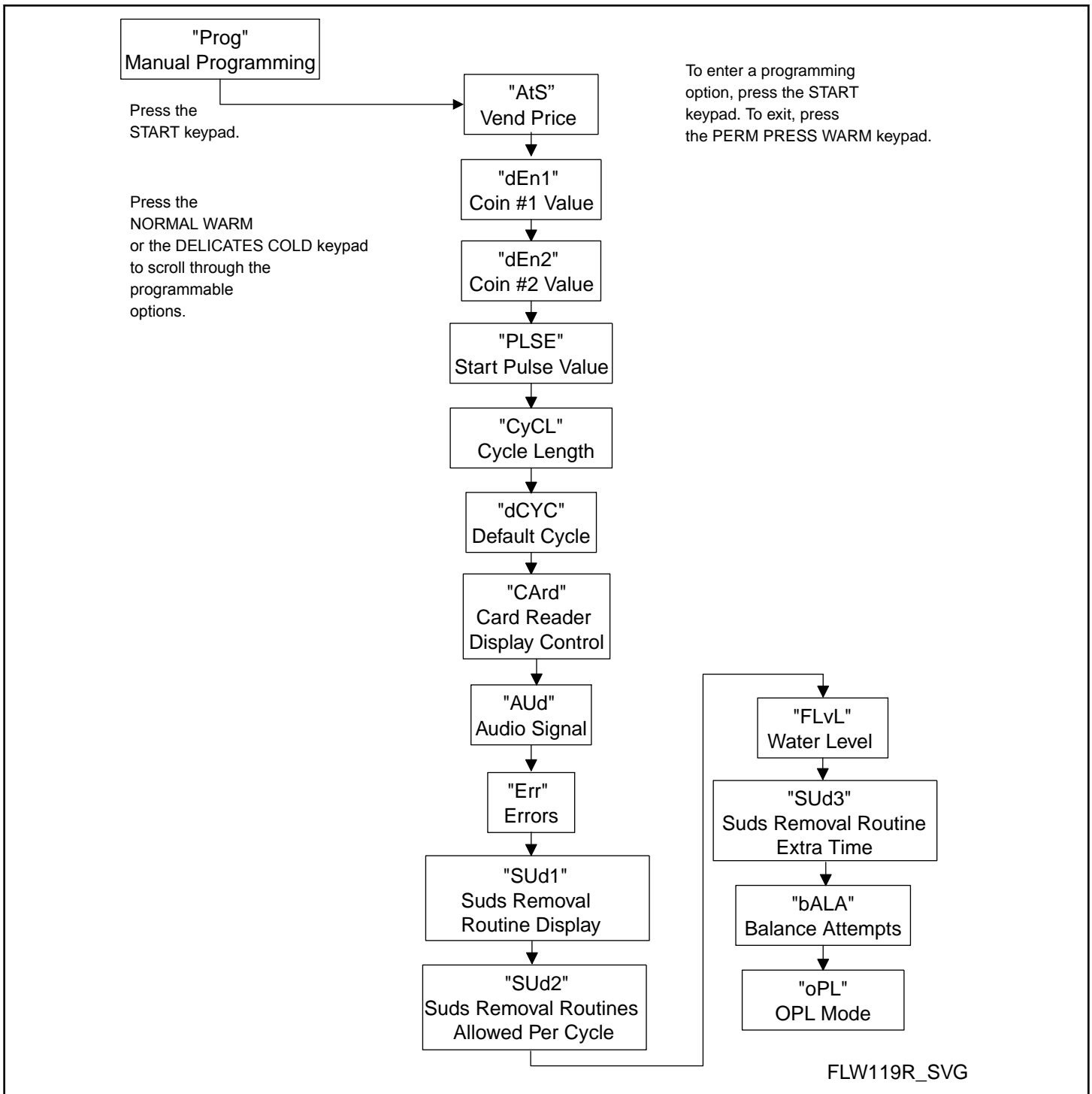

Figure 5

Vend Price $\#E5$

1. Control must be in Manual Mode. Refer to *How to Enter the Manual Mode*.
2. Press the NORMAL WARM (A) or the DELICATES COLD (V) keypad until **Prø9** appears in the display. Press the START (enter) keypad. $\#E5$ will appear in the display.
3. Press the START (enter) keypad. All LEDs will be lit to show which cycle/temperature price is being programmed.
4. Press the NORMAL WARM (A) or the DELICATES COLD (V) keypad to increase or decrease the value of the fifth digit.
NOTE: The vend price can be set from 0 to 65,535. The factory default setting is 200.

5. Press the START (enter) keypad to enter the fifth digit and display remaining four digits. The active digit will flash one second on and one second off.

NOTE: To go back to the current programmable option without changing the value, press the PERM PRESS WARM (<) keypad.

6. Press the NORMAL WARM (A) or the DELICATES COLD (V) keypad to increase or decrease the value of the active digit and the START (enter) keypad to enter the value of the digit and advance to the next digit.
7. Press the START (enter) keypad when the correct value appears in the display. The new value is saved and the next option will appear in the display.

Coin 1 Value $dEn1$

This option allows the owner to set a specific numerical value for a coin entered. For example, in the United States the coin value for one quarter would be measured in cents (25). Therefore, the coin value entered for one quarter would be 00025.

If the Vend Price is set for “.75”, and the Coin Value is set for “00025”, the vend price displayed will decrease by 0.25 for each coin entered and 3 coins will need to be entered to satisfy the vend price.

1. Control must be in Manual Mode. Refer to *How to Enter the Manual Mode*.
2. Press the NORMAL WARM (A) or the DELICATES COLD (V) keypad until **Prø9** appears in the display. Press the START (enter) keypad, and $\#E5$ will appear in the display.
3. Press the NORMAL WARM (A) or the DELICATES COLD (V) keypad to scroll through the programmable options until $dEn1$ appears in the display.
4. When $dEn1$ appears in the display, press the START (enter) keypad. There are five digits in the Coin 1 Value. The fifth digit will appear in the display and will flash one second on, one second off.
5. Press the NORMAL WARM (A) or the DELICATES COLD (V) keypad to increase or decrease the value of the fifth digit.

NOTE: The coin value can be set from 1 to 65,535. The factory default setting is 25.

6. Press the START (enter) keypad to enter the fifth digit and display remaining four digits. The active digit will flash one second on and one second off.

NOTE: To go back to the current programmable option without changing the value, press the PERM PRESS WARM (<) keypad.

7. Press the NORMAL WARM (A) or the DELICATES COLD (V) keypad to increase or decrease the value of the active digit and the START (enter) keypad to enter the value of the digit and advance to the next digit.
8. Press the START (enter) keypad when the correct value appears in the display. The new value is saved and the next option will appear in the display.

Coin 2 Value $dEn2$

This option allows the owner to set a specific numerical value for a coin entered when using a dual coin drop. For example, the coin value for a dollar coin would be measured in cents (1.00). Therefore, the coin value entered for one dollar coin would be 00100.

If the Vend Price is set for “2.00”, and the Coin Value is set for “00100”, the vend price displayed will decrease by 1.00 for each dollar coin entered.

1. Control must be in Manual Mode. Refer to *How to Enter the Manual Mode*.
2. Press the NORMAL WARM (A) or the DELICATES COLD (V) keypad until **Prø9** appears in the display. Press the START (enter) keypad, and $\#E5$ will appear in the display.
3. Press the NORMAL WARM (A) or the DELICATES COLD (V) keypad to scroll through the programmable options until $dEn2$ appears in the display.
4. When $dEn2$ appears in the display, press the START (enter) keypad. There are five digits in the Coin 2 Value. The fifth digit will appear in the display and will flash one second on, one second off.
5. Press the NORMAL WARM (A) or the DELICATES COLD (V) keypad to increase or decrease the value of the fifth digit.

NOTE: The coin value can be set from 1 to 65,535. The factory default setting is 100.

6. Press the START (enter) keypad to enter the fifth digit and display remaining four digits. The active digit will flash one second on and one second off.

NOTE: To go back to the current programmable option without changing the value, press the PERM PRESS WARM (<) keypad.

7. Press the NORMAL WARM (A) or the DELICATES COLD (V) keypad to increase or decrease the value of the active digit and the START (enter) keypad to enter the value of the digit and advance to the next digit.

- Press the START (enter) keypad when the correct value appears in the display. The new value is saved and the next option will appear in the display.

Start Pulse Value *PLSE*

This option allows the owner to program the value of the Start Pulse if used for multiple pulses with an after-market central card reader or pay system.

- Control must be in Manual Mode. Refer to *How to Enter the Manual Mode*.
- Press the NORMAL WARM (A) or the DELICATES COLD (V) keypad until *Prø9* appears in the display. Press the START (enter) keypad, and *Æ5* will appear in the display.
- Press the NORMAL WARM (A) or the DELICATES COLD (V) keypad to scroll through the programmable options until *PLSE* appears in the display.
- When *PLSE* appears in the display, press the START (enter) keypad. There are five digits in the Start Pulse Value. The fifth digit will appear in the display and will flash one second on, one second off.
- Press the NORMAL WARM (A) or the DELICATES COLD (V) keypad to increase or decrease the value of the fifth digit.
NOTE: The Start Pulse Value can be set from 1 to 65,535. The factory default setting is 25.
- Press the START (enter) keypad to enter the fifth digit and display remaining four digits. The active digit will flash one second on and one second off.
NOTE: To go back to the current programmable option without changing the value, press the PERM PRESS WARM (<) keypad.
- Press the NORMAL WARM (A) or the DELICATES COLD (V) keypad to increase or decrease the value of the active digit and the START (enter) keypad to enter the value of the digit and advance to the next digit.
- Press the START (enter) keypad when the correct value appears in the display. The new value is saved and the next option will appear in the display.

Cycle Length *LYCL*

- Control must be in Manual Mode. Refer to *How to Enter the Manual Mode*.
- Press the NORMAL WARM (A) or the DELICATES COLD (V) keypad until *Prø9* appears in the display. Press the START (enter) keypad, and *Æ5* will appear in the display.
- Press the NORMAL WARM (A) or the DELICATES COLD (V) keypad to scroll through the programmable options until *LYCL* appears in the display.
- When *LYCL* appears in the display, press the START (enter) keypad.

NOTE: To go back to the current programmable option without changing the value, press the PERM PRESS WARM (<) keypad.

- Press the NORMAL WARM (A) or the DELICATES COLD (V) keypad to change the current value.

Value	Description
3	1 wash and 2 rinses
4	1 wash and 3 rinses
5	1 prewash, 1 wash, 3 rinses

- Press the START (enter) keypad when the correct value appears in the display. The new value is saved and the next option will appear in the display.

Default Cycle *dLYC*

This option allows the owner to set the default cycle that the machine will enter when in the Ready Mode.

- Control must be in Manual Mode. Refer to *How to Enter the Manual Mode*.
- Press the NORMAL WARM (A) or the DELICATES COLD (V) keypad until *Prø9* appears in the display. Press the START (enter) keypad, and *Æ5* will appear in the display.
- Press the NORMAL WARM (A) or the DELICATES COLD (V) keypad to scroll through the programmable options until *dLYC* appears in the display.
- When *dLYC* appears in the display, press the START (enter) keypad. A number will appear in the display. Refer to table below. This number corresponds to the current default cycle value. The corresponding LEDs will also be lit.

Cycle	Display
NORMAL HOT	<i>LYC1</i>
NORMAL WARM	<i>LYC2</i>
NORMAL COLD	<i>LYC3</i>
PERM PRESS WARM	<i>LYC4</i>
DELICATES COLD	<i>LYC5</i>

Table 1

- Press the NORMAL WARM (A) or the DELICATES COLD (V) keypad to increase or decrease the current number to the desired number.
- Press the START (enter) keypad when the correct value appears in the display. The new value is saved and the next option will appear in the display.

Card Reader Display Control *CRd*

This option allows the owner to program whether the display is controlled by the machine’s electronic control or an external payment system such as a card reader.

NOTE: This feature does not need to be programmed manually. The card reader itself makes this determination.

1. Control must be in Manual Mode. Refer to *How to Enter the Manual Mode*.
2. Press the NORMAL WARM (Λ) or the DELICATES COLD (V) keypad until *Prø9* appears in the display. Press the START (enter) keypad, and *RL5* will appear in the display.
3. Press the NORMAL WARM (Λ) or the DELICATES COLD (V) keypad to scroll through the programmable options until *CRd* appears in the display.
4. When *CRd* appears in the display, press the START (enter) keypad. The current Card Reader Display Control Status will appear in the display.

on = Card Reader/External Payment System controls display

oFF = Machine Electronic Control controls display (factory default setting)

5. Press the NORMAL WARM (Λ) or the DELICATES COLD (V) keypad to change the current status.
6. Press the START (enter) keypad when the correct value appears in the display. The new value is saved and the next option will appear in the display.

Audio Signal *AUD*

This option allows the owner to program an audio signal on or off.

There are four occasions when a signal may sound during the washer operation. These four occasions are listed below:

1. **Keypad Depression Signal** By default, this signal is turned on and will sound for a quarter of a second. This signal will sound each time a keypad is pressed.
2. **Coin Input/Card Insertion Signal** By default, this signal is turned on and will sound for a quarter of a second each time a coin or card is entered.
3. **Remove Card Signal (Card Models Only)** By default, this signal is turned on and will sound one second on and one second off when the control is prompting for card removal.
4. **Signal for Start** By default, this signal is turned on and will sound one second on and one second off for 10 seconds after vend price has been satisfied.

How to Program the Audio Signal

1. Control must be in Manual Mode. Refer to *How to Enter the Manual Mode*.

2. Press the NORMAL WARM (Λ) or the DELICATES COLD (V) keypad until *Prø9* appears in the display. Press the START (enter) keypad, and *RL5* will appear in the display.
3. Press the NORMAL WARM (Λ) or the DELICATES COLD (V) keypad to scroll through the programmable options until *AUD* appears in the display.
4. When *AUD* appears in the display press the START (enter) keypad. *on* or *oFF* will appear in the display.
5. Press the NORMAL WARM (Λ) or the DELICATES COLD (V) keypad to change the current value.
6. Press the START (enter) keypad when the correct value appears in the display. The next option will appear in the display.

Error Code Programming *Err*

This option allows the owner to turn on or turn off the control's error codes.

1. Control must be in Manual Mode. Refer to *How to Enter the Manual Mode*.
2. Press the NORMAL WARM (Λ) or the DELICATES COLD (V) keypad until *Prø9* appears in the display. Press the START (enter) keypad, and *RL5* will appear in the display.
3. Press the NORMAL WARM (Λ) or the DELICATES COLD (V) keypad to scroll through the programmable options until *Err* appears in the display.
4. When *Err* appears in the display, press the START (enter) keypad. The current status will appear in the display.
5. Press the NORMAL WARM (Λ) or the DELICATES COLD (V) keypad to turn the error codes *on* or *oFF*.
6. Press the START (enter) keypad when the desired option appears in the display. Refer to *Table 2* for a list of the error codes that will be turned off or on.

Error Code Programming <i>Err</i>
Coin Error Penalty - If enabled, coin error will erase previous coins entered and reset the vend price.
Vend Header Present Error - If enabled and coin drop header is unplugged, control ignores coin inputs.
Fill Error - If enabled, will set error after 30 minutes if fill level isn't reached. If disabled will allow filling forever if fill level never reached.
No Water Flow Error - If enabled, will set error after 5 minutes if 4 inch water level isn't reached. If disabled will allow filling forever until 4 inch level is reached.

Table 2 continues...

Error Code Programming <i>Err</i>
Drain Error - If Enabled, will set error after 15 minutes if empty water level isn't reached. If disabled will allow draining forever if empty level never reached.
Water Leak Detection Error - This error checks for whether the machine is leaking water by adding 1 minute to the cycle to check for water leaks.
Slow Drain Detection Error - Is used to detect for slow draining conditions. Helps allow for locations with poor draining conditions.
Non-Fatal Unbalance Error - Error shown at end of cycle if load has been detected to be out of balance during the cycle. Shown after the door is opened or a key is pressed. This error will remain displayed until another key has been pressed or one minute passes.
Suds Lock Error Display - Shown at end of cycle after the door is opened or a key is pressed if suds were still detected in the machine after all Suds Removal Routines allowed have been run in the cycle. Will be cleared after one minute or if a key is pressed.

Table 2

Water Level *FLUL*

This option allows the owner to set the low, medium and high water levels which can be used in fill steps to set water levels in cycle programming.

1. Control must be in Manual Mode. Refer to *How to Enter the Manual Mode*.
2. Press the NORMAL WARM (Λ) or the DELICATES COLD (V) keypad until **Prø9** appears in the display. Press the START (enter) keypad, and **RL5** will appear in the display.
3. Press the NORMAL WARM (Λ) or the DELICATES COLD (V) keypad to scroll through the programmable options until **FLUL** appears in the display.
4. When **FLUL** appears in the display, press the START (enter) keypad to enter the display the current value.
5. Press the NORMAL WARM (Λ) or the DELICATES COLD (V) keypad to change the water level between 1 and 30.
6. Press the START (enter) keypad when the correct value appears in the display. The new value is saved and the next option will appear in the display.

Number of Balance Attempts with No Loss of Time *bALR*

This option allows the owner to program the machine's number of balance attempts with no loss of time. If the machine needs to re-balance for any reason, time will pause for additional balance at-

tempts when this parameter is greater than 1. A value of 1 allows for the normal allocated time. Further attempts beyond the programmed value will not pause cycle time. This may result in lower max spin speeds and time.

1. Control must be in Manual Mode. Refer to *How to Enter the Manual Mode*.
2. Press the NORMAL WARM (Λ) or the DELICATES COLD (V) keypad until **Prø9** appears in the display. Press the START (enter) keypad, and **RL5** will appear in the display.
3. Press the NORMAL WARM (Λ) or the DELICATES COLD (V) keypad to scroll through the programmable options until **bALR** appears in the display.
4. When **bALR** appears in the display, press the START (enter) keypad. The current Number of Balance Attempts with no Loss of Time will appear in the display.
5. Press the NORMAL WARM (Λ) or the DELICATES COLD (V) keypad to change the current value. The factory default setting is 3.
6. Press the START (enter) keypad when the correct value appears in the display. The new value is saved and the next option will appear in the display.

OPL Parameters *oPL*

This option allows the owner to enable or disable the OPL Parameters in which no vend price needs to be satisfied to operate the machine.

1. Control must be in Manual Mode. Refer to *How to Enter the Manual Mode*.
2. Press the NORMAL WARM (Λ) or the DELICATES COLD (V) keypad until **Prø9** appears in the display. Press the START (enter) keypad, and **RL5** will appear in the display.
3. Press the NORMAL WARM (Λ) or the DELICATES COLD (V) keypad to scroll through the programmable options until **oPL** appears in the display.
4. When **oPL** appears in the display, press the START (enter) keypad to enter the OPL submenu.
5. Press the NORMAL WARM (Λ) or the DELICATES COLD (V) keypad to scroll through the OPL submenu options.
6. Press the START (enter) keypad when the desired option appears in the display.

Collecting Audit Information

This feature allows the owner to retrieve audit information stored in the washer by pressing a sequence of pads on the control.

How to Enter Audit Feature

There are two methods the owner can use to enter the Audit Feature.

Entering the Audit Feature by Manual Mode

1. Control must be in Manual Mode. Refer to *How to Enter the Manual Mode*.
2. Press the NORMAL WARM (A) or the DELICATES COLD (V) keypad to scroll through the programmable options until **AUDt** appears in the display.
3. Press the START keypad and **CYC** will appear in the display.

Entering the Audit Feature with the Coin Vault Open

1. Open coin vault. Make sure service door is closed.
2. Press the START (enter) keypad.

How to Read Audit Data

1. Press the NORMAL WARM (A) or the DELICATES COLD (V) keypad to scroll through the programmable options. Refer to *Table 3*.
2. When the desired option appears in the display press the START (enter) keypad. The current value will appear in the display. The display will show the audit value. If the audit count is 10,000 or higher, the first of five digits will display. Then press the START (enter) keypad again to view the last four digits of the number.

NOTE: The display can show up to 4 digits at one time. Audit counts 10,000 or higher are separated into two 4-digit segments. Each time the START (enter) keypad is pressed in step 2, the display will show the next 4-digit segment in the audit value. If the value is 9,999 or less, only one 4-digit segment will be shown.

For Example: In the Total Number of Coins #1 option with “Coi1” shown in the display, the audit has counted 10,009 coins. Pressing the START (enter) keypad one time will show “___1” to represent ten thousand. Pressing the START (enter) keypad a second time will display “0009” meaning nine. The total equals “10009” or 10,009.

3. Press the PERM PRESS WARM keypad. The display will return to the audit option list.

Programmable Options	
CYC	Total Number of Machine Cycles
Coi1	Total Number of Coins #1
Coi2	Total Number of Coins #2
PLSE	Total Number of Start Pulses

Table 3

How to Exit Audit Feature

1. Press the PERM PRESS WARM (<) keypad until the control returns to Ready Mode.
2. To exit Audit Feature when using Coin Vault Open method, owner must close coin vault. The control will then return to Ready Mode.

Manual Reset

This feature allows the owner to reset the washer control's programming data to the factory default settings by pressing a sequence of pads on the control.

How to Enter Manual Reset

1. Control must be in Manual Mode to start. Refer to *How to Enter the Manual Mode*.
2. Press the NORMAL WARM (Λ) or the DELICATES COLD (V) keypad until **r5Et** appears in the display.
3. Press the START (enter) keypad. **no** will appear in the display.
4. Press the NORMAL WARM (Λ) or the DELICATES COLD (V) keypad to change the value to **YPS**.
5. Press the START (enter) keypad to reset the control to the factory default settings.

Testing Machine and Electronic Control Functions

This feature allows the owner to run diagnostic tests on various washer operations without servicing the washer. The following tests are available:

- Front-End Control Software Version # Test
- Drive Board #1 Software Version Test
- Service Door Switch Input Test
- Coin Vault Switch Input Test
- Coin Drop #1 Input Test
- Coin Drop #2 Input Test
- Vend Connection Header Present Input Test
- Start Pulse Input Test
- Door Switch Input Test*
- Door Lock Switch Input Test*
- Show Fill Time Test
- Show Drain Time Test
- Out of Balance Switch Input Test
- External Output Test*
- Water Purge Test*
- Water Leak Detection Test*
- Water Level Test
- DC Bus Voltage Test
- AC Mains Voltage Test
- Machine Configuration #1 Display Test
- Machine Configuration #2 Display Test
- Machine Configuration #3 Display Test
- Machine Configuration #4 Display Test
- Machine Configuration #5 Display Test

* Tests can only be entered when in Start or Ready Mode.

For an overview of the manual diagnostic test feature, refer to the flowchart on the following page.

How to Enter Testing Feature

1. Control must be in Manual Mode. Refer to *How to Enter the Manual Mode*.
2. Press the NORMAL WARM (Λ) or the DELICATES COLD (V) keypad to scroll through the programmable options until **d1 R9** appears in the display.
3. Press the START (enter) keypad. Display will change to **d 1** indicating the control software version number test.
4. Press the NORMAL WARM (Λ) or the DELICATES COLD (V) keypad to scroll through the diagnostic test options.

How to Start Tests

1. To start a diagnostic test, refer to the quick reference chart below.
2. Press the START (enter) keypad when the desired test number is displayed. For detailed information on each test, read the appropriate description.

How to Exit Testing Feature

Press the PERM PRESS WARM (<) keypad until the display returns to the previous mode of operation.

Diagnostic (Testing) Mode – Quick Reference Chart

Test Number	Diagnostic Mode	Display
d 1	Control Software Version # Test	5 ---
d 3	Driver Board #1 Software Version Test	db --
d 8	Service Door Opening Test	5 aP or 5 LL
d 9	Coin Vault Opening Test	u aP or u LL
d 10	Coin Drop #1 Input Test	11 --
d 11	Coin Drop #2 Input Test	12 --
d 12	Vend Header Present Status Test	CH aP (Open) or CH LL (Closed)

Table 4 continues...

Test Number	Diagnostic Mode	Display
<i>d 13</i>	Start Pulse Test	<i>St --</i>
<i>d 15</i>	Door Switch Input Test	<i>dr oP, dr CL</i>
<i>d 16</i>	Door Lock Input Test	<i>CLoS door</i>
<i>d 17</i>	Show Fill Time Test	<i>F---</i>
<i>d 18</i>	Show Drain Time Test	<i>d---</i>
<i>d 22</i>	Out of Balance Switch Input Test	<i>bR oP or bR CL</i>
<i>d 23</i>	External Output Test	<i>ES - or - on</i>
<i>d 24</i>	Water Purge Test	<i>CLoS, door, PURG or FL5H</i>
<i>d 25</i>	Water Leak Detection Test	<i>PASS, E Ld, E LF or Ld CLoS, door</i>
<i>d 26</i>	Water Level Test	<i>L --- or L ---.</i>
<i>d 27</i>	DC Bus Voltage Test	<i>---.-</i>
<i>d 28</i>	AC Mains Voltage Test	<i>---.-</i>
<i>d 29</i>	Machine Configuration #1 Display Test	<i>A ---</i>
<i>d 30</i>	Machine Configuration #2 Display Test	<i>b ---</i>
<i>d 31</i>	Machine Configuration #3 Display Test	<i>C ---</i>
<i>d 32</i>	Machine Configuration #4 Display Test	<i>d ---</i>
<i>d 33</i>	Machine Configuration #5 Display Test	<i>E ---</i>

Table 4

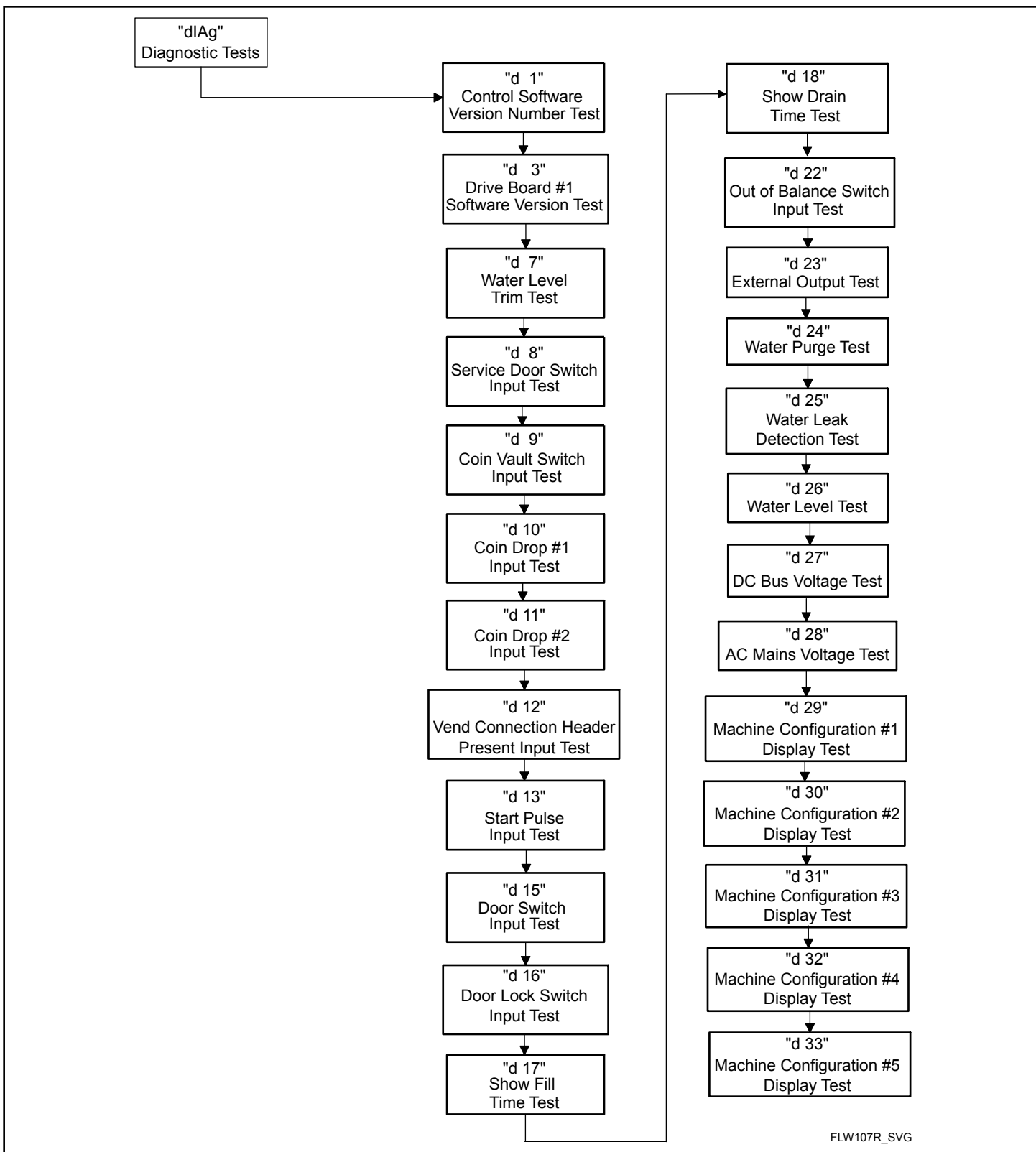

FLW107R_SVG

Figure 6

Diagnostic Test Descriptions

Control Software Version Number Test *d 1*

This option displays the control software version number. To start test, control must be in the Testing Mode. Refer to *How to Enter Testing Feature* at the beginning of this section.

To enter, press the START (enter) keypad. The display will show **5 HH** where **HH** is the software version number.

To exit the Software Version Number Test, press the PERM PRESS WARM (<) keypad. The control will return to the Testing Mode.

Drive Board #1 Software Test *d 3*

This option displays the drive board software version number. To start test, control must be in the Testing Mode. Refer to *How to Enter Testing Feature* at the beginning of this section.

To enter, press the START (enter) keypad. The display will show **db IHH** where **HH** is the software version number.

To exit the Drive Board #1 Version Test, press the PERM PRESS WARM (<) keypad. The control will return to the Testing Mode.

Water Level Trim Test *d 7*

This test checks the water level trim value. To start test, control must be in the Testing Mode. Refer to *How to Enter Testing Feature* at the beginning of this section.

To enter, press the START (enter) keypad. The display will show **LRHH** where **XX** is the trim value in 0.1 inch precision where a value of **05** would equal 0.5 inches. If the right most decimal point is lit, the trim value is negative.

To exit the Water Level Trim Test, press the PERM PRESS WARM (<) keypad. The control will return to the Testing Mode.

Service Door Opening Test *d 8*

This option tests the service door switch. To start test, control must be in the Testing Mode. Refer to *How to Enter Testing Feature* at the beginning of this section.

To enter, press the START (enter) keypad. The display will show **5 oP** when the service door switch is open and **5 LL** when the service door switch is closed.

The service door switch has to be closed for at least one second and opened for at least one second for the display to change. This test will add a count to the service door opening counter for the audit and save the date/time for each opening.

To exit the Service Door Opening Test, press the PERM PRESS WARM (<) keypad. The control will return to the Testing Mode.

Coin Vault Opening Test *d 9*

This option tests the coin vault switch. To start test, the control must be in the Testing Mode. Refer to *How to Enter Testing Feature* at the beginning of this section.

To enter, press the START (enter) keypad. The display will show **u oP** when the coin vault switch is open and **u LL** when the coin vault switch is closed.

The coin vault switch has to be closed for at least one second and opened for at least one second for the display to change. This test will add a count to the coin vault opening counter for the audit and save the time/date for each opening.

To exit the Coin Vault Opening Test, press the PERM PRESS WARM (<) keypad. The control will return to the Testing Mode.

Coin Drop 1 Input Test *d 10*

This option tests coin drop #1. To start test, control must be in the Testing Mode. Refer to *How to Enter Testing Feature* at the beginning of this section.

To enter, press the START (enter) keypad. The display will show **L I HH**. The **HH** will show the number of coins entered and will increment one for each coin entered in coin drop #1.

NOTE: Coins entered in test mode will not increment the total # of coins counter that is accessed in the audit feature.

To exit the Coin Drop #1 Input Test, press the PERM PRESS WARM (<) keypad. The control will return to the Testing Mode.

Coin Drop 2 Input Test *d 11*

This option tests coin drop #2. To start test, control must be in the Testing Mode. Refer to *How to Enter Testing Feature* at the beginning of this section.

To enter, press the START (enter) keypad. The display will show **L2 HH**. The **HH** will show the number of coins entered and will increment one for each coin entered in coin drop #2.

NOTE: Coins entered in test mode will not increment the total # of coins counter that is accessed in the audit feature.

To exit the Coin Drop #2 Input Test, press the PERM PRESS WARM (<) keypad. The control will return to the Testing Mode.

Vend Connection Header Present Test *d 12*

This option tests the vend header connection. To start test, control must be in Testing Mode. Refer to *How to Enter Testing Feature* at the beginning of this section.

To enter, press the START (enter) keypad. The display will show **LH oP** when the wiring connection is open and **LH LL** when the connection is closed.

To exit Vend Connection Header Present Test, press the PERM PRESS WARM (<) keypad. The control will return to the Testing Mode.

Start Pulse Test d 13

This option tests the Start Pulse. To start test, control must be in the Testing Mode. Refer to *How to Enter Testing Feature* at the beginning of this section.

To enter, press the START (enter) keypad. The display will show **5E HH**. The **HH** will show the number of pulses entered. This test will add counts to the total number of Start Pulses counter. Refer to *Collecting Audit Information*.

To exit the Start Pulse Test, press the PERM PRESS WARM (<) keypad. The control will return to the Testing Mode.

Door Switch Input Test d 15

This test will display whether the washer door is open or closed.

To start test, control must be in the Testing Mode. Refer to *How to Enter Testing Feature* at the beginning of this section.

To enter, press the START (enter) keypad. If the door is closed, the display will show **dr LL**. If the door is open, the display will show **dr oP**.

To exit the test, press the PERM PRESS WARM (<) keypad. The control will return to the Testing Mode.

Door Lock Input Test d 16

This test will display whether the door is locked or unlocked.

To start test, control must be in the Testing Mode. Refer to *How to Enter Testing Feature* at the beginning of this section.

To enter, close the door and press the START (enter) keypad. The control will lock the door. If the door is open, the display will show **LLo5** and **door**. The door must be closed to enter test.

If the door is unlocked, the display will show **dr UL**. After the door is locked, the display shows **dr Lo** and 5 seconds later the door will unlock. This sequence is repeated every time the START (enter) keypad is pressed.

To exit the test, press the PERM PRESS WARM (<) keypad. The control will return to the Testing Mode.

Show Fill Time Test d 17

This test will display the average fill time. This average will be calculated by taking the average of the last 10 fill times.

To start test, control must be in the Testing Mode. Refer to *How to Enter Testing Feature* at the beginning of this section.

To enter, press the START (enter) keypad. The display will show **FHHH**. The **HHH** will be the average fill time in seconds.

To exit the Show Fill Time Test, press the PERM PRESS WARM (<) keypad. The control will return to the Testing Mode.

Show Drain Time Test d 18

This test will display the average drain time. This average will be calculated by taking the average of the last 10 drain times.

To start test, control must be in the Testing Mode. Refer to *How to Enter Testing Feature* at the beginning of this section.

To enter, press the START (enter) keypad. The display will show **dHHH**. The **HHH** will be the average fill time in seconds.

To exit the Show Drain Time Test, press the PERM PRESS WARM (<) keypad. The control will return to the Testing Mode.

Out of Balance Switch Test d 22

This test displays whether the out of balance switch is open or closed. To start test, control must be in the Testing Mode. Refer to *How to Enter Testing Feature* at the beginning of this section.

To enter, press the START (enter) keypad. The display will show **bA oP** if the switch is open or **bA LL** if the switch is closed.

To exit the Out of Balance Switch Test, press the PERM PRESS WARM (<) keypad. The control will return to the Testing Mode.

External Outputs Test d 23

This test will allow any one of the external outputs to be selected. To start test, control must be in the Testing Mode. Refer to *How to Enter Testing Feature* at the beginning of this section.

To enter, press the START (enter) keypad. The display will show **E5 H** where X is the output number. Press the NORMAL WARM (Λ) or the DELICATES COLD (v) keypad to scroll through the outputs.

Press the START (enter) keypad to energize the selected external output. **H oN** will be displayed. Press the START (enter) again or the PERM PRESS WARM (<) keypad to turn off the selected external output.

To exit the External Outputs Test, press the PERM PRESS WARM (<) keypad. The control will return to the Testing Mode.

Water Purge Test d 24

This test allows the user to test water removal from the machine. To start test, control must be in the Testing Mode. Refer to *How to Enter Testing Feature* at the beginning of this section.

To enter, press the START (enter) keypad. The display will show **PUr9** and the START (enter) keypad LED will flash. Begin the test by pressing START (enter). If the door is open, **LLo5**, **door** will be displayed to prompt the user to close the loading door. When the START (enter) pad is pressed with the door closed, the door will lock and **FL5H** will be displayed.

The control will energize all water valves and supply outputs while keeping the drain valves open or the pump energized. Press any keypad to end the test. The test will end automatically after 2 minutes. The door will unlock and the control will display **PUr9**.

To exit the Water Purge Test, press the PERM PRESS WARM (<) keypad. The control will return to the Testing Mode.

Water Leak Detection Test *d 25*

This test allows the user to check for water leaking from the machine. To start test, control must be in the Testing Mode. Refer to *How to Enter Testing Feature* at the beginning of this section.

To enter, press the START (enter) keypad. The display will show **L d** and the START (enter) keypad LED will flash. Begin the test by pressing START (enter). If the door is open, **CLoS, door** will be displayed to prompt the user to close the loading door. When the START (enter) pad is pressed with the door closed, the door will lock and the test will begin. With the drain valve closed or the pump off, the cold water valve will turn on until the Low water level is reached.

After a 10 second pause to allow the water pressure to stabilize, the control will record the current water level from the electronic water level sensing input and continue to monitor the water level for two minutes. The display will show a sequence of horizontal LED segments to indicate it is monitoring the water level.

After two minutes, the control will compare the ending water level with the level at the start. If the water level has dropped or raised, the display will show **E L d** to signify a drain leak or **E L F** to signify a fill leak. If the water level has not dropped or raised, the display will show **PASS**.

Then the drain will open or the pump will turn on. When the water has been drained or pumped out of the machine, the control will unlock the door and display the result message. The error message is an indication to the machine owner that there should be service attention devoted to the fill valve or drain valve/pump on the machine to diagnose where the water leak is originating.

To stop the test while it is running, press the START (enter) keypad. The test will stop, the machine will drain the water, unlock the door, and the control will go back to the beginning of the test sequence.

To exit the Water Leak Detection Test, press the PERM PRESS WARM (<) keypad. The control will return to the Testing Mode.

Water Level Test *d 25*

This test displays the water level as determined by the water level sensor. To start test, control must be in the Testing Mode. Refer to *How to Enter Testing Feature* at the beginning of this section.

To enter, press the START (enter) keypad. The display will show **L HHH** where **HHH** is the water level in 0.1 inch precision where a value of 05 equals 0.5 inches. If the rightmost decimal point is lit, the value is negative.

To exit the Water Level Test, press the PERM PRESS WARM (<) keypad. The control will return to the Testing Mode.

DC Bus Voltage Test *d 27*

This will display the DC Bus Voltage. To start test, control must be in the Testing Mode. Refer to *How to Enter Testing Feature* at the beginning of this section.

To enter, press the START (enter) keypad. The display will show **HHHH** which is the voltage in 0.1 Volt precision.

To exit the DC Bus Voltage Test, press the PERM PRESS WARM (<) keypad. The control will return to the Testing Mode.

AC Mains Voltage Test *d 28*

This will display the AC Mains Voltage. To start test, control must be in the Testing Mode. Refer to *How to Enter Testing Feature* at the beginning of this section.

To enter, press the START (enter) keypad. The display will show **HHHH** which is the voltage in 0.1 Volt precision.

To exit the AC Mains Voltage Test, press the PERM PRESS WARM (<) keypad. The control will return to the Testing Mode.

Configuration 1 Display Test *d 29*

This option shows the machine configuration values. To start test, control must be in the Testing Mode. Refer to *How to Enter Testing Feature* at the beginning of this section.

To enter, press the START (enter) keypad. For configuration value #1, the display will show **# HHH.HH** is a number corresponding to whether or not coin drops are connected, a card reader or network board are connected, or whether the life-test jumper is present. Refer to *Table 5*.

To exit a Configuration Display Test, press the PERM PRESS WARM (<) keypad. The control will return to the Testing Mode.

Each column of the table below contains a unique combination of the words "YES" and "NO" that indicates if that column's connection is present.

Configura- tion Value	Life Test Jumper Present	Comm Board "B" Header Present	Comm Board "A" Header Present	Vend Con- nection Present	Coin Drop #2 Present	Coin Drop #1 Present
0	NO	NO	NO	NO	NO	NO
1	NO	NO	NO	NO	NO	YES
2	NO	NO	NO	NO	YES	NO
3	NO	NO	NO	NO	YES	YES
4	NO	NO	NO	YES	NO	NO
5	NO	NO	NO	YES	NO	YES
6	NO	NO	NO	YES	YES	NO
7	NO	NO	NO	YES	YES	YES
8	NO	NO	YES	NO	NO	NO
9	NO	NO	YES	NO	NO	YES
10	NO	NO	YES	NO	YES	NO
11	NO	NO	YES	NO	YES	YES
12	NO	NO	YES	YES	NO	NO
13	NO	NO	YES	YES	NO	YES
14	NO	NO	YES	YES	YES	NO
15	NO	NO	YES	YES	YES	YES
16	NO	YES	NO	NO	NO	NO
17	NO	YES	NO	NO	NO	YES
18	NO	YES	NO	NO	YES	NO
19	NO	YES	NO	NO	YES	YES
20	NO	YES	NO	YES	NO	NO
21	NO	YES	NO	YES	NO	YES
22	NO	YES	NO	YES	YES	NO
23	NO	YES	NO	YES	YES	YES
24	NO	YES	YES	NO	NO	NO
25	NO	YES	YES	NO	NO	YES
26	NO	YES	YES	NO	YES	NO
27	NO	YES	YES	NO	YES	YES
28	NO	YES	YES	YES	NO	NO
29	NO	YES	YES	YES	NO	YES
30	NO	YES	YES	YES	YES	NO

Table 5 *continues...*

Configura- tion Value	Life Test Jumper Present	Comm Board "B" Header Present	Comm Board "A" Header Present	Vend Con- nection Present	Coin Drop #2 Present	Coin Drop #1 Present
31	NO	YES	YES	YES	YES	YES
32	YES	NO	NO	NO	NO	NO
33	YES	NO	NO	NO	NO	YES
34	YES	NO	NO	NO	YES	NO
35	YES	NO	NO	NO	YES	YES
36	YES	NO	NO	YES	NO	NO
37	YES	NO	NO	YES	NO	YES
38	YES	NO	NO	YES	YES	NO
39	YES	NO	NO	YES	YES	YES
40	YES	NO	YES	NO	NO	NO
41	YES	NO	YES	NO	NO	YES
42	YES	NO	YES	NO	YES	NO
43	YES	NO	YES	NO	YES	YES
44	YES	NO	YES	YES	NO	NO
45	YES	NO	YES	YES	NO	YES
46	YES	NO	YES	YES	YES	NO
47	YES	NO	YES	YES	YES	YES
48	YES	YES	NO	NO	NO	NO
49	YES	YES	NO	NO	NO	YES
50	YES	YES	NO	NO	YES	NO
51	YES	YES	NO	NO	YES	YES
52	YES	YES	NO	YES	NO	NO
53	YES	YES	NO	YES	NO	YES
54	YES	YES	NO	YES	YES	NO
55	YES	YES	NO	YES	YES	YES
56	YES	YES	YES	NO	NO	NO
57	YES	YES	YES	NO	NO	YES
58	YES	YES	YES	NO	YES	NO
59	YES	YES	YES	NO	YES	YES
60	YES	YES	YES	YES	NO	NO
61	YES	YES	YES	YES	NO	YES

Table 5 *continues...*

Configura- tion Value	Life Test Jumper Present	Comm Board "B" Header Present	Comm Board "A" Header Present	Vend Con- nection Present	Coin Drop #2 Present	Coin Drop #1 Present
62	YES	YES	YES	YES	YES	NO
63	YES	YES	YES	YES	YES	YES

Table 5

Configuration 2 Display Test d 30

This option is not used on this model.

Configuration 3 Display Test d 31

This option is not used on this model.

Configuration 4 Display Test d 32

This option shows the user which dipswitches are set on the control.

To start test, control must be in the Testing Mode. Refer to *How to Enter Testing Feature* at the beginning of this section.

To Enter, press the START (enter) keypad. The display will show **d HHH** with **HHH** representing a configuration value as shown in *Table 6*.

If supply voltage is 100-127 Volt per phase, the voltage configuration should be 120 Volt.

If supply voltage is 200-240 Volt per phase, the voltage configuration should be 240 Volt.

To exit Machine Configuration 4 Display Test, press the PERM PRESS WARM (<) keypad. The control will return to the Testing Mode.

Each column in the table below contains a unique combination of the words "ON" and "OFF" that indicates if that column's dipswitch is set on or off when the value is displayed.

Configuration Value	Dipswitch 8 Pump (OFF) Gravity Drain (ON)	Dipswitch 7 Heater Disabled (OFF) Heater Enabled (ON)	Dipswitch 3 Payment System Not Present (OFF) Payment System Present (ON)	Dipswitch 2 Energy Cycle	Dipswitch 1 120 Volt Supply (OFF) 240 Volt Supply (ON)
0	OFF	OFF	OFF	OFF	OFF
1	OFF	OFF	OFF	OFF	ON
2	OFF	OFF	OFF	ON	OFF
3	OFF	OFF	OFF	ON	ON
4	OFF	OFF	ON	OFF	OFF
5	OFF	OFF	ON	OFF	ON
6	OFF	OFF	ON	ON	OFF
7	OFF	OFF	ON	ON	ON
64	OFF	ON	OFF	OFF	OFF
65	OFF	ON	OFF	OFF	ON

Table 6 continues...

Configuration Value	Dipswitch 8 Pump (OFF) Gravity Drain (ON)	Dipswitch 7 Heater Disabled (OFF) Heater Enabled (ON)	Dipswitch 3 Payment System Not Present (OFF) Payment System Present (ON)	Dipswitch 2 Energy Cycle	Dipswitch 1 120 Volt Supply (OFF) 240 Volt Supply (ON)
66	OFF	ON	OFF	ON	OFF
67	OFF	ON	OFF	ON	ON
68	OFF	ON	ON	OFF	OFF
69	OFF	ON	ON	OFF	ON
70	OFF	ON	ON	ON	OFF
71	OFF	ON	ON	ON	ON
128	ON	OFF	OFF	OFF	OFF
129	ON	OFF	OFF	OFF	ON
130	ON	OFF	OFF	ON	OFF
131	ON	OFF	OFF	ON	ON
132	ON	OFF	ON	OFF	OFF
133	ON	OFF	ON	OFF	ON
134	ON	OFF	ON	ON	OFF
135	ON	OFF	ON	ON	ON
192	ON	ON	OFF	OFF	OFF
193	ON	ON	OFF	OFF	ON
194	ON	ON	OFF	ON	OFF
195	ON	ON	OFF	ON	ON
196	ON	ON	ON	OFF	OFF
197	ON	ON	ON	OFF	ON
198	ON	ON	ON	ON	OFF
199	ON	ON	ON	ON	ON

Table 6

Configuration 5 Display Test *d 33*

This option is not used on this model.

Factory Test

To Enter Factory Test

1. Be certain control is in Ready Mode or Start Mode and access panel or coin vault is open.
2. While pressing and holding the NORMAL COLD modifier keypad with one hand, press the PERM PRESS WARM keypad with the other hand.
3. When the control enters Factory Test, it will display the first test step, Machine Type.
4. The control will advance through the sequence of test steps whenever START (enter) is pressed, with the exception of the Keypad Test and Pressure Sensor Test. Refer to the table below for all tests in the Factory Test.

To Exit Factory Test

To exit a test step, disconnect the machine from electrical power.

Factory Test Quick Reference Chart		
Display	Test Mode	Comments
<i>FL</i>	Control Type	FL is the control type.
<i>S H H H</i>	Software Version Number	XXX is the control version number.
<i>R H</i>	Control Level	The control will display the control level as Display 1.
<i>d r R</i> , or <i>P U N P</i>	Drain Type	The control will show <i>d r R</i> , if it is configured for a gravity drain. It will show <i>P U N P</i> if it is configured as an electric pump machine. The control will remain in this mode until the Start keypad is pressed.
<i>H E A L</i>	Heater Installed	The control will show <i>H E A L</i> if it is configured for a Water Heater. The control will skip this step if it is not configured for a Water Heater. The control will remain in this mode until the Start keypad is pressed.
<i>u o P</i> or <i>u C L</i>	Coin Vault Test	<i>u o P</i> is displayed when coin vault switch is open. <i>u C L</i> is displayed when coin vault switch is closed.
<i>S o P</i> or <i>S C L</i>	Service Door Switch Test	<i>S o P</i> is displayed when service door switch is open. <i>S C L</i> is displayed when service door switch is closed.
<i>C H C H</i>	Coin Drop Test	X is the number of coins entered. Coin drop #1 is shown on the left of the display and coin drop #2 is shown on the right of the display.
<i>C A R d</i> , <i>L C S U</i> , or <i>S U</i>	Card Reader Test	<i>C A R d</i> is displayed when a card reader is completed but not driving the display. <i>L C S U</i> is displayed when a programming/setup card is needed. <i>S U</i> is displayed when a programming/setup card was successful.
<i>P A H H</i>	Keypad Test	XX is the number of the keypad being pressed. You need to press all keypads to advance to the next step.

Table 7 continues...

Factory Test Quick Reference Chart		
Display	Test Mode	Comments
BBBB	Display Test	All LEDs and display segments will light.
dr oP or dr CL	Door Switch Test	dr oP is displayed when loading door is open. dr CL is displayed when loading door is closed.
dbHH	Driver Type and Driver Version Number	Driver board version display when XX is the driver software version number.
drLo or drUL	Door Lock Test	When step is entered, control will lock door and will then check to make sure door is locked. drLo is displayed if door is locked. drUL is displayed if door is unlocked.
CLdE	Cold/Detergent Fill	Cold Water Fill valve and Detergent/ Bleach valve are turned on.
HoSF	Hot/Softener Fill	Hot Water Fill valve and Softener valve are turned on.
PrSr	Pressure Sensor Fill	This step checks the water level input. The display shows PrSt , and all water valves turn on. When the Water Fill Level is satisfied, the water valves are turned off. If the Start key is pressed and the Water Fill level is not satisfied, the control will not advance to the next cycle step.
oFL o	Overflow Test	All water and dispenser valves are turned on. When the overflow level is reached the water valves are turned off. If the START (enter) key is pressed and the Water Fill level is not satisfied, the control will not advance to the next cycle step.
LoAG	Low Agitate	Machine enters low agitate.
rER o	Regular Agitate	Machine enters regular agitate.
PUNP or drA i	Pump/Gravity Drain Test	Pump is turned on or gravity drain is opened. The control will not advance to next step until drum is empty.
RPM speed displayed HHHH	Spin Test	Machine will attempt to spin up to 1200 RPMs.

Table 7 continues...

Factory Test Quick Reference Chart		
Display	Test Mode	Comments
<i>brAY</i>	Breakaway	<p>Motor runs at Regular Agitate speed. When door unlocks, open door to exit test.</p> <p>Start keypad must be pressed three times to advance to next step. First press turns off water, second press stops motor and third press unlocks the door.</p>
<i>Pd</i>	Power Down	<p>This is the final step of Factory Test. The control will display <i>Pd</i> to signify that factory test has been completed and that the user can safely unplug the machine. Cycling power to the machine is the only way to resume normal operation and the control will stay in this state indefinitely until that time.</p>

Table 7

Error Codes

Following is a list of possible error codes for an electronic control. Errors beginning with **EC** refer to card reader errors. All other errors refer to machine errors.

NOTE: Fatal Errors will show *out of order* along with the error on the display.

Error Codes		
Display	Description	Cause/Corrective Action
ECHH	Payment System Error	The Front-end control communicates with the Payment System in order to perform vending transactions. If an error should occur, which, terminates communication during a transaction, the LED Display will show ECHH for a control generated error, where the HH represents an error code.
EC02	Time-out Error	Communication failure. Try card again.
EC03	Invalid Command Code	Communication successful, but the command was not valid for this machine type, or the control could not perform the command in its current mode of operation. Ensure data is for current machine type and control is in correct mode.
EC05	Invalid or Out-of-Range Data	The value in at least one of the programming options is invalid or out of range. Re-check the programming option's value and try again.
EC 11	No Card Reader Initialization	Communication is valid, but there is no card reader initialization. Power down, power up and try again.
EC 18	No Communication	Card reader is initialized, communication lost. Power down, power up and try again. If error persists, replace control or card reader.
EC 19	No Card Reader Communication	Communication failure. Power down, power up and try again. If error persists, replace control or card reader.
Right most decimal point Lit	Water Leak Detection Error or Slow Drain Detection Error	Water leak test has detected a water leak during a cycle or slow drain is detected in the drain step of a running cycle. The decimal point will remain lit after the error display has expired. Clear the decimal point by pressing the START keypad three times within five seconds or by cycling the power to the machine.
Right most decimal point blinking	Machine ID Error	Machine ID is no longer communicating with the control. Check Machine ID connection.
Left most decimal point blinking one second on/one second off	Max Speed Fail Error	If the final spin fails to reach 1200 RPM, the control will set the Max Speed Fail Error immediately when entering End of Cycle Mode to alert that the max speed was not reached in the cycle. This error will be cleared when vend is entered, a key is pressed, the door is opened, or when higher priority errors are cleared.
E FL	Fill Error	Fill level is not reached within 30 minutes (or other programmed length of time) in any fill step.
E dL	Door Lock Fatal Error	Door is unlocked during a running cycle. To clear this error, cycle power to the machine.

Table continues...

Error Codes		
Display	Description	Cause/Corrective Action
<i>E dL 1</i>	Door Lock Non-Fatal Error	If the door fails to lock in twenty (20) seconds in Door Locking Mode after the Drive has been enabled the control will turn off all outputs and show the error <i>E dL 1</i> . To clear this error the door must either open or lock.
<i>E dL 2</i>	Door Unlock Non-Fatal Error	If the door fails to unlock in 20 seconds, with a solenoid type door lock, after the drum has stopped spinning, and all other outputs have been turned off, the control will show error <i>E dL 2</i> . To clear this error the door must unlock or open.
<i>E do</i>	Door Opened During A Running Cycle	Control detects door open and door locked inputs high. Can be caused by pulling on door while locked or about to lock. Correct inoperative door locking system. Unpower machine to clear error.
<i>E Ub 1</i>	Non-Fatal Unbalance Error	Unable to balance load. Redistribute load and run cycle.
<i>E Ub 2</i>	Fatal Unbalance Error	Wires to unbalance switch broken or not connected.
<i>ELoS door</i>	Door Open Indicator	Door is not closed during an active cycle. If door is closed, check for improper wiring or faulty door switch.
<i>Err</i>	Coin Error	Invalid coin pulse or inoperative coin sensor. Check coin drop area and remove obstructions. If error persists, tampering may have occurred. Evaluate security procedures.
<i>E id</i>	Board ID	Incorrect replacement control. Replace user control or output board with the correct part.
<i>E d5</i>	Brownout/Voltage Configuration	Unexpected supply voltage. Check the harness connections between the user control and the output board. If the user control was replaced, set dip switch #1 to the same setting as the previous control. If reworking the machine to use a different voltage supply, the dip switch #1 setting may need to be changed. If the dip switch #1 setting is changed, power down, power up and try again.
<i>E nr</i>	Drive/Output Board Not Ready	Hardware failure. Try cycling power to machine before replacing output board.
<i>E b5</i>	Drive/Output Board Shorted	Hardware failure. Try cycling power to machine before replacing output board.
<i>En</i>	Machine ID Errors	
<i>En 31</i>	Product Byte #1 Mis-Match	Product family does not match between the Machine ID Control and Front End Control. Replace Machine ID Control with one meant for current Front End Control platform.
<i>En 32</i>	Product Byte #2 Mis-Match	Machine type does not match between the Machine ID Control and Front End Control (frontload washer vs. dryer). Replace Machine ID Control and/or front end control with one meant for current machine type.

Table continues...

Error Codes		
Display	Description	Cause/Corrective Action
<i>E_n 33</i>	Product Byte #3 Mis-Match	Control level does not match between the Machine ID Control and Front End Control (A4 vs. A2). Replace Machine ID Control with a properly configured A level for the control being attached. Use Factory Test Procedure to determine front end control's control level.
<i>E_n 39</i>	Corrupted Data on Machine ID Control	Try cycling power to machine. If error continues, check for damage to Machine ID Control and harness and/or replace Machine ID Control with a correctly configured Machine ID Control.
<i>E_n 3E</i>	Machine control cannot be configured with the Machine ID Control in the machine	Try cycling power to machine. If error continues, check for damage to Machine ID Control and harness and/or replace Machine ID Control with a correctly configured Machine ID Control.
<i>E_n 3F</i>	Cannot communicate with the Machine ID Control	Try cycling power to machine. If error continues, check for damage to Machine ID Control and harness and/or replace Machine ID Control with a correctly configured Machine ID Control.
<i>E C_o</i>	Drive/Output Board Communication Error	Communication failure. Power down, power up and try again. If error persists, check connection between user control and output board, or try replacing the user control or the output board.
<i>E dr</i>	Drain Error	If the control has the drain error enabled the control will enter Machine Error Mode when the water height is not below the empty level, after attempting to drain for the programmable time (default 15 minutes). In the event of a drain error, the control will turn off all outputs and turn on the Machine Error Tone for 15 seconds.
<i>E 5d</i>	Slow Drain Error	If a slow drain is detected in the Drain step of a running cycle, the machine control will light the right-most decimal point. The decimal point will remain illuminated after the slow drain error display has expired, to draw the attention of the owner or attendant. The decimal point can be cleared by pressing the START keypad 3 times in a period of 5 seconds, or by cycling the power to the machine.
<i>E 5L</i>	Suds Lock Error	In the spin steps, if the control determines that there are suds in the machine after running all programmed Suds Routines, it will display a Suds Lock Error at the end of the cycle after the door is opened. The control will continue showing this error code until any key has been pressed or for one minute.
<i>E Ld</i>	Water Leak Drain Error	Error will display if there is a leak after the door is opened at the End of Cycle for 1 minute. Clears after 1 minute or until a key is pressed. If the water level has dropped more than an acceptable amount in a during a water leak drain check, the control will save a water leak drain error status and will continue the machine cycle. Immediately upon detecting the error the right-most decimal point will be lit. This lit decimal point can be cleared by pressing the START keypad 3 times in a period of 5 seconds or by cycling the power to the machine.

Table continues...

Error Codes		
Display	Description	Cause/Corrective Action
<i>E nF</i>	No Water Flow Error	If the control does not reach a water level of 4 inches within the programmed time it may mean the hose to the pressure sensor has a leak or no water is flowing into the machine. The control will enter Machine Error mode. The control will first drain for 90 seconds and then turn off all outputs and turn on the Machine Error Tone for 15 seconds. To clear this error one of the following must occur: the machine must be powered down, the Clear Fatal Error Keys must be pressed, or a Clear Fatal Error Network command must be sent.
<i>E oF</i>	Overflow Error	The machine must be powered down, the Clear Fatal Error Keys must be pressed, or a Clear Fatal Error Network command must be sent. This error is triggered when an unsafe high water level is detected in the machine and water is unable to drain.
<i>E PS</i>	Pressure Sensor Error	If the control does not detect a valid water level sensor input for thirty (30) seconds, or if the Max (Overflow) Fill Level in the control is set to 0 while in Run Mode, Factory Test Mode, or Overflow Mode, the control will enter Machine Error Mode. The control will first drain for thirty (30) seconds to get out any water, and unlock the door. To clear this error one of the following must occur: the machine must be powered down, the Clear Fatal Error Keys must be pressed, or a Clear Fatal Error Network command must be sent.
<i>E tr</i>	Trim Error	The machine must be powered down, the Clear Fatal Error Keys must be pressed or a Clear Fatal Error Network command must be sent.
<i>E bb</i>	Broken Belt Error	If a broken belt is ever detected by the control, the control will show error this error code. To clear this error one of the following must occur: the machine must be powered down, the Clear Fatal Error Keys must be pressed, or a Clear Fatal Error Network command must be sent.
<i>E LF</i>	Water Leak Fill Error	If the water level has raised more than an acceptable amount in a during a water leak check, the control will save a water leak error status and will continue the machine cycle. Immediately upon detecting the error the right-most decimal point will be lit. This lit decimal point can be cleared by pressing the START keypad 3 times in a period of 5 seconds or by cycling the power to the machine.
Display is dim		Look for loose pins and damaged wires on harness from user control to drive board.
<i>E d</i>	Drive Board Errors	
<i>E d 10</i>	Voltage Select Error	Wrong Input Voltage seen at drive board 120V vs 240V. Dip switch 1 on FEC set wrong, or possibly water on drive board (let drive dry out and determine cause of water). Unpower to clear error. Replace drive board if error persists.
<i>E d 12</i>	Over Voltage AC-Main Input Error	Machine voltage is too high, check supply voltage to the machine and verify that it is within machine specifications. Unpower to clear error. Replace drive board if error persists.
<i>E d 13</i>	Power Fail Dangerous Error	The Neutral Line power input to the machine was seen out of range. Unpower to clear error. Check for damage in the power supply harness. Replace power supply harness or drive board if error persists.

Table continues...

Error Codes		
Display	Description	Cause/Corrective Action
<i>E d 21</i>	Over Voltage DC Bus Error	Unpower to clear error. Check voltage input to machine. If it happens only at start of spin, replace motor. Replace drive board if error persists.
<i>E d 22</i>	Over Motor Temperature Error	Motor temperature is detected to be too high. Check that drum spins freely when empty. Check for overloading of machine. Check motor harness for damage. Reduce agitation time and duty cycle if rotate/pause times are very short and programmable. Unpower to clear error. Replace drive board if error persists.
<i>E d 23</i>	Fatal IPM Over Current Shunt Error	Check that drum and motor spins freely. Unpower to clear error. Check the motor phase windings. Continuity should be uniform between phases L1 and L2, L2 and L3, L1 and L3. Replace motor if not uniform. Replace drive board if error persists.
<i>E d 24</i>	Fatal I2T Hardware Over Current Error	Check that drum and motor spins freely. Rotor may be locked up. Check the motor phase windings. Continuity should be uniform between phases L1 and L2, L2 and L3, L1 and L3. Replace motor if not uniform. Unpower to clear error. Replace drive board if error persists.
<i>E d 25</i>	IPM Over Temperature Error	IPM temperature is detected to be too high. Check that drum spins freely when empty, check for overloading of machine, reduce agitation time, and duty cycle if rotate/pause times are very short and programmable. Unpower to clear error. Check for lint build-up on heat sink on drive board. Replace drive board if error persists.
<i>E d 29</i>	Motor Not Connected Error	The motor or one of its electrical phases is not connected. Check that the harness from the motor to the drive board is fully plugged in on both ends and that there is no damage to the motor harness. Make sure to push in the motor harness on both ends just in case it is a little loose and not fully inserted. If the harness looks fine and the error still occurs, try replacing the drive board or harness. Unpower to clear error.
<i>E d 44</i>	Overcurrent Shunt Detection Circuit Fail Error	Hardware failure. Unpower to clear error. Replace drive board if error persists.
<i>E d 45</i>	Door Lock Pin HW On/Off Fail Error	Hardware failure. Unpower to clear error. Replace drive board if error persists.
<i>E d 46</i>	Heater Pin HW On/Off Fail	Hardware failure. Unpower to clear error. Replace drive board if error persists.
<i>E d 47</i>	Hot Valve Pin HW On/Off Fail	Hardware failure. Unpower to clear error. Replace drive board if error persists.
<i>E d 48</i>	Cold Valve Pin HW On/Off Fail	Hardware failure. Unpower to clear error. Replace drive board if error persists.
<i>E d 49</i>	Detergent Valve Pin HW On/Off Fail	Hardware failure. Unpower to clear error. Replace drive board if error persists.
<i>E d 50</i>	Softener Valve Pin HW On/Off Fail	Hardware failure. Unpower to clear error. Replace drive board if error persists.

Table continues...

Error Codes		
Display	Description	Cause/Corrective Action
<i>E d 51</i>	Inrush Pin HW On/Off Fail	Hardware failure. Unpower to clear error. Replace drive board if error persists.
<i>E d 52</i>	Voltage Doubler Pin HW On/Off Fail	Hardware failure. Unpower to clear error. Replace drive board if error persists.
<i>E d 53</i>	Door Lock Select Voltage Pin HW On/Off Fail	Hardware failure. Unpower to clear error. Replace drive board if error persists.
<i>E d 54</i>	Pump Pin HW On/Off Fail	Hardware failure. Unpower to clear error. Replace drive board if error persists.
<i>E d 55</i>	Fatal NTC Short Error	Check heater thermistor and thermistor wiring for damage. Unpower to clear error. Replace drive board if error persists.
<i>E d 56</i>	Fatal NTC Open Error	Check heater thermistor and thermistor wiring for damage. Unpower to clear error. Replace drive board if error persists.
<i>E d 63</i>	Fatal IPM Temperature Short Error	Hardware failure. Unpower to clear error. Replace drive board if error persists.
<i>E d 64</i>	Fatal IPM Temperature Open Error	Hardware failure. Unpower to clear error. Replace drive board if error persists.

Rapid Advance Feature

This feature allows the user to quickly advance through an active cycle or advance into a cycle from the Ready Mode. This feature is useful when tests must be performed immediately on a machine currently in an active cycle. In this case, the user can quickly advance through the cycle to the Ready Mode. At this point, the user can perform the required tests and then return the machine to the active cycle.

How to Enter Rapid Advance

1. Control must be in Manual Mode. Refer to *How to Enter the Manual Mode*.
2. Press the NORMAL WARM (Λ) or the DELICATES COLD (V) keypad to scroll through the programmable options until **rRPd** appears in the display.
3. Press the START (enter) keypad. The display will show **PUSH** then **Start** followed by the cycle time and the START (enter) keypad LED will flash.
4. Press the START (enter) keypad to start cycle or, if already in an active cycle, pressing START (enter) keypad will advance to the next cycle step.
NOTE: Door must be closed to start cycle.
5. Continue pressing the START (enter) keypad until the cycle is completed.

How to Exit Rapid Advance Feature

Advance through the cycle until reaching the Ready Mode.

Power Fail Recovery

The Power Fail Recovery feature allows the cycle status to be saved in memory in the event of a power failure.

If the power failure lasted less than 5 seconds and the door is locked, the cycle will resume without requiring the user to press the START (enter) keypad to restart.

If the power failure lasted longer than 5 seconds, the control will require the user to press the START (enter) keypad to restart.

Communications Mode

Card Reader Communications - Card Models Only

The Card Reader Communications feature allows the washer control to communicate with the card reader. The washer control can be programmed for a limited number of options and have its data read without using the keypad.

Default Cycle Time

The cycle lengths listed are the default cycle times programmed at the factory. The cycle length can be modified by adding a pre-wash or additional rinses. Refer to *Cycle Length CyCL*.

NORMAL COLD is the default cycle.

Description	Step Number	Step Type	Step Time (Minutes:Seconds)
Initial Drain	1	Extract	0:10
Prewash (Active with Cycle Length Parameter set to 5)	2	Fill	2:30
	3	Supply	0:30
	4	Agitate	1:30
	5	Cooldown	-
	6	Extract	2:00
Wash (Using wetting fill)	7	Fill	2:30
	8	Supply Detergent/Bleach; ES1, ES2	0:30
	9	Agitate	Normal = 3:00 Perm Press = 2:30 Delicate = 2:00
	10	Cooldown	-
	11	Extract	Normal & Perm Press = 4:20 Delicate = 4:05
Rinse 1	12	Fill	2:00
	13	Agitate	0:35
	14	Extract	Normal & Perm Press = 4:20 Delicate = 4:05
Rinse 2 (Active with Cycle Length Parameter set to 4 or 5)	15	Fill	2:00
	16	Agitate	0:35
	17	Extract	Normal & Perm Press = 4:20 Delicate = 4:05
Rinse 3 (Disabled)	18	Fill	2:00
	19	Agitate	0:35
	20	Extract	Normal & Perm Press = 4:20 Delicate = 4:05

Table continues...

Description	Step Number	Step Type	Step Time (Minutes:Seconds)
Rinse 4	21	Fill	2:00
	22	Supply Softener; ES3, ES4	0:30
	23	Agitate	0:35
Final Extract	25	Extract	Normal = 9:50 Perm Press = 8:20 Delicate = 7:20
Shakeout	25	Agitate	0:40
Total Time			Normal = 30:00 Perm Press = 28:00 Delicate = 26:00